



ISO 9001:2008 REGISTERED
P.O. Box 551 • Edinboro, PA 16412
Phone: 814-734-7303 • Fax: 814-734-3907

A&E Specs: 2 Post Racks



Please Note: Specifications for 2 Post Rack GLRR-1984 and 2 Post Rack GLRR-1984BA are identical, excluding finish. These differences are notes below.

General

The two (2) post rack must be Great Lakes product model GLRR-1984 and GLRR-1984BA. The Two Post Rack shall be UL listed to UL60950-1 (Standard for Information Technology and Communications Equipment, Cabinet, Enclosure and Rack Systems.). Dimensions shall be 84.00”H x 20.31”W x 14.00”D. Weight capacity shall be 1500 lbs.

Finish for GLRR-1984: Rack must be made out of acid etched anodized extruded aluminum.

Finish for GLRR-1984BA: Rack must be made out of black anodized extruded aluminum rails.

Rail Mounting: Rack shall be double sided and must have 45 rack mount units (RMU). Holes shall be tapped #12-24, Rack shall be 19” EIA 310-D Compliant Mtg.

Rack components must contain: two (2) vertical uprights, two (2) base angles, two (2) top angles, twelve (12) 1/2”-13 x 1” hex-head bolts, twelve (12) 1/2” lock washers, fifty (50) 12-24 x 1/2 mounting hardware. Unit must be able to be networked to other racks and accept vertical cable management part number 1984-VCM10. Manufacturer must be ISO 9001:2008 registered.

Drawings

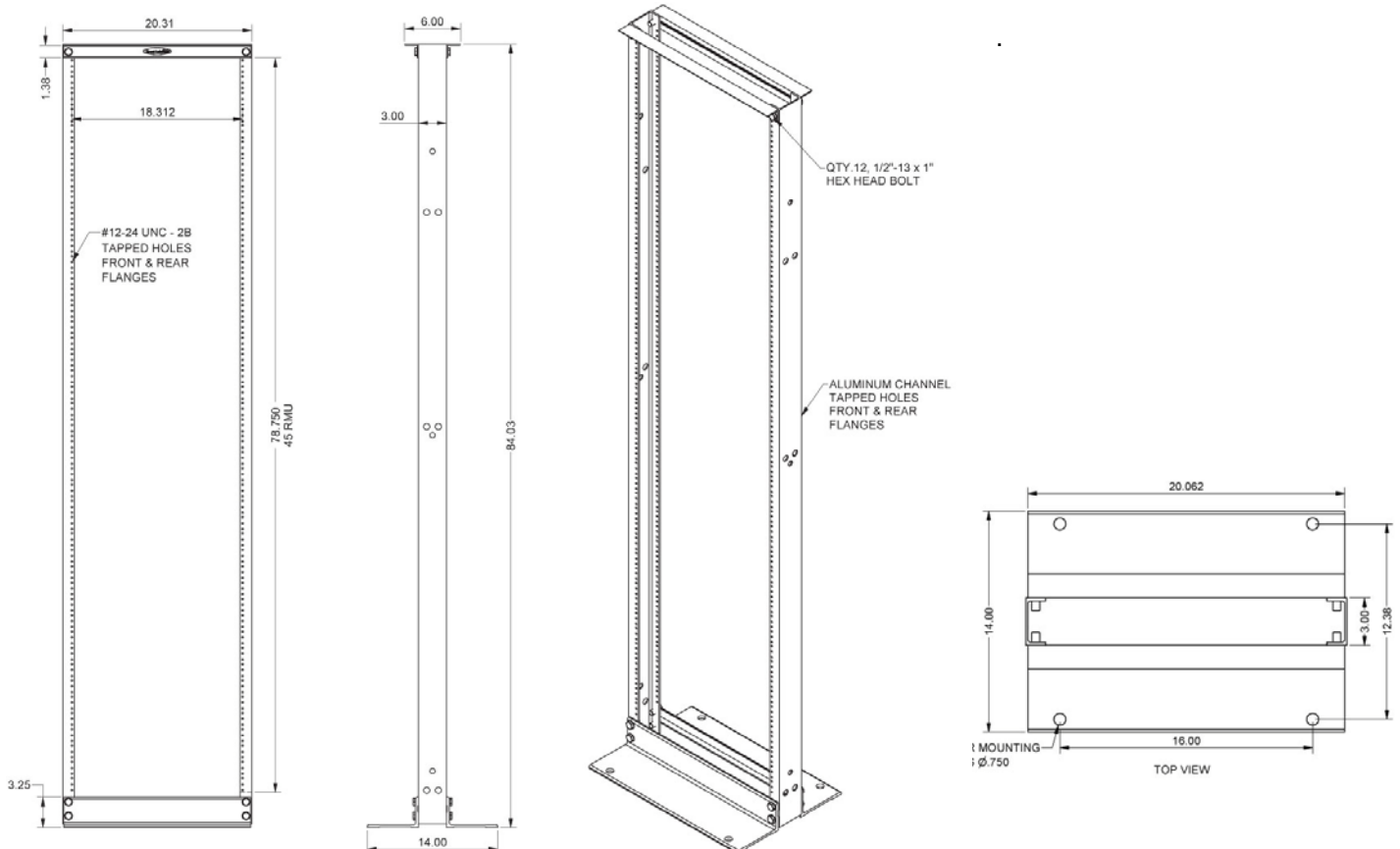

Popular Accessories

Part No	Description
1984ST09	Stationary Shelf, 19.00"W x 9.00"D, 75 lb. weight capacity
1984ST15	Stationary Shelf, 19.00"W x 15.00"D, 75 lb. weight capacity
1984-KM	Keyboard Shelf with Pivoting Mouse Tray, 19.00"W x 8.00"D, 35 lb. weight capacity
7215-20ARTLP-PSBK	16 position, 20 amp power strip with circuit breaker, 15 ft. cord and mounting brackets
7219	6 position, 15 amp power strip with circuit breaker and 15 ft. cord for 19" mounting
1984-VCM10	7"H x 10.00"D Double-sided Vertical Cable Manager with 6.00"W x 5.00"D cable runs
1984-VCM10C	Single Hinged cover for 1984-VCM10
CM-07	Waterfall Cable Management Trough
FMSBKT	Universal (EIA equipment) front mount support brackets with hardware
1984LR	Ladder Rack Support Bracket; Mounts parallel or perpendicular to the rack; Works with 12", 15", and 18" ladder racks

1984-VCM10 & CM-07



1984-KM



Includes Great Lakes Mouse Pad (keyboard and mouse shown for demonstration).

1984LR



Shown with attached ladder rack (for demonstration).