

REVISION HISTORY			
REV	DESCRIPTION	DATE	APPROVED
0	ECO-01341	10/25/2004	WSS

EXTENSION ASSEMBLY

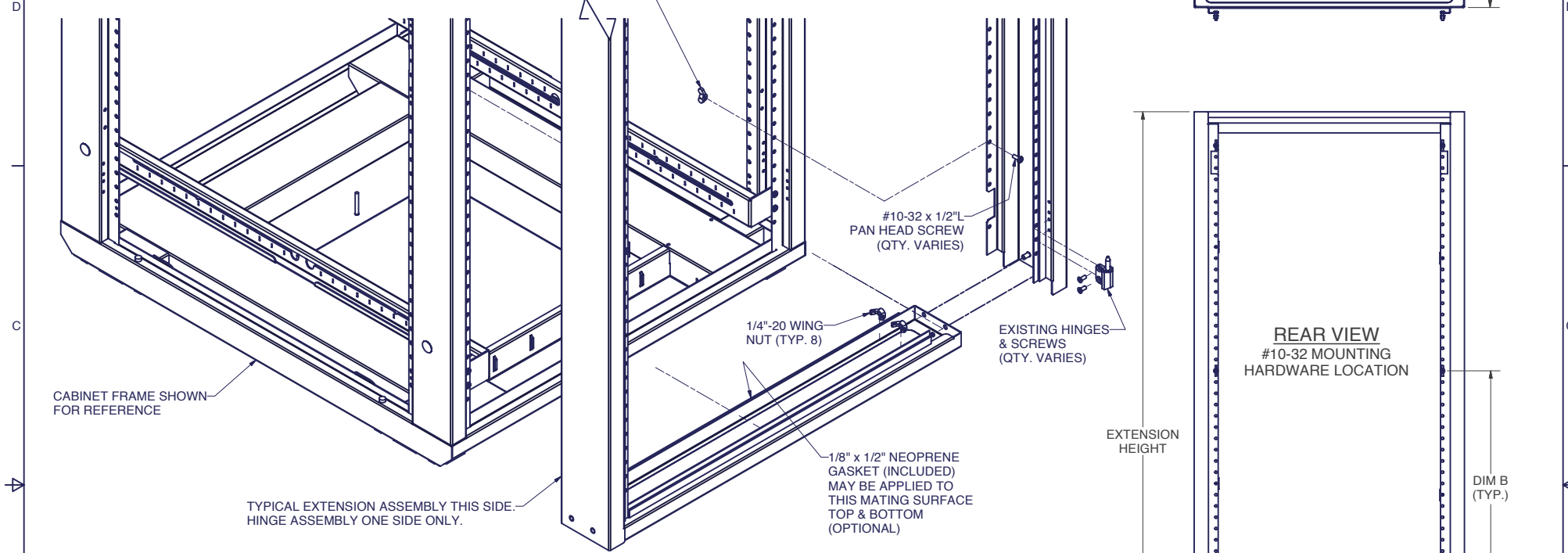

NOTES:

- 1.) CUSTOMER TO ASSEMBLE ON SITE. PHILLIPS HEAD SCREWDRIVER ONLY REQUIRED.
- 2.) DOOR AND HINGES MUST BE REMOVED FROM EXISTING CABINET FRAME PRIOR TO EXTENSION INSTALLATION.
- 3.) FULLY ASSEMBLE EXTENSION TO CABINET FRAME BEFORE TIGHTENING ALL SCREWS.
- 4.) AFTER EXTENSION IS MOUNTED, THE DOOR AND HINGES MAY BE MOVED TO THE EXTENSION.
- 5.) EXTENSION MAY BE STACKED TOGETHER TO ACHIEVE GREATER DEPTH REQUIRED.

72E24EXT4 72E29EXT4 78E24EXT4 84E24EXT4 84E29EXT4

Cabinet Height (in)	72.0	72.0	78.0	84.0	84.0
Extension Height (in)	70.0	70.0	76.0	82.0	82.0
Extension Width (in)	24.0	29.0	24.0	24.0	29.0
Mounting Screws per Side	5	5	5	5	5
Dim A (in)	7.0	7.0	8.0	9.0	9.0
Dim B (in)	14.0	14.0	15.0	16.0	16.0
Hinges per Door	3	3	3	3	3



INTERPRET DRAWING PER ASME Y14.5M-1994
 DIMENSIONAL LIMITS APPLY AFTER APPLICATION OF FINISH
 DRAWING NOT TO SCALE
 TOLERANCE UNLESS OTHERWISE NOTED:
 ANGULAR +/- 1-
 .XXXX +/- .010
 .XXX +/- .015
 .XX +/- .030
 X FOR REF. ONLY
 UNLESS OTHERWISE SPECIFIED ALL DIMENSIONS ARE IN INCHES

NOTICE:
 Use of this document is subject to a confidentiality and nondisclosure agreement with Great Lakes Case & Cabinet Co., Inc. (GLCC) and may not be reproduced, disclosed or utilized in whole or in part without prior written authorization from GLCC.

PART NUMBER: **ICEXT4**
 QTY PER UNIT: 1
 MATERIAL TYPE:
 MATERIAL GAUGE:
 FINISH: -
 DRAWN DATE: 12/30/2003
 CHECKED & APP. DATE: 10/25/2004
 WSS

TITLE: **4" CABINET EXTENSION INSTRUCTIONS**
GREAT LAKES CASE & CABINET CO., INC.
 P.O. BOX 551 EDINBORO, PA 16412
 PHONE (814) 734-7303 FAX (814) 734-3907
 E-MAIL glcc@greatcabinets.com
 DWG NO: **I002578**
 REV: **0**
 SHEET: 1 OF 2

POWER STRIP BRACKET ASSEMBLY

REAR VIEW

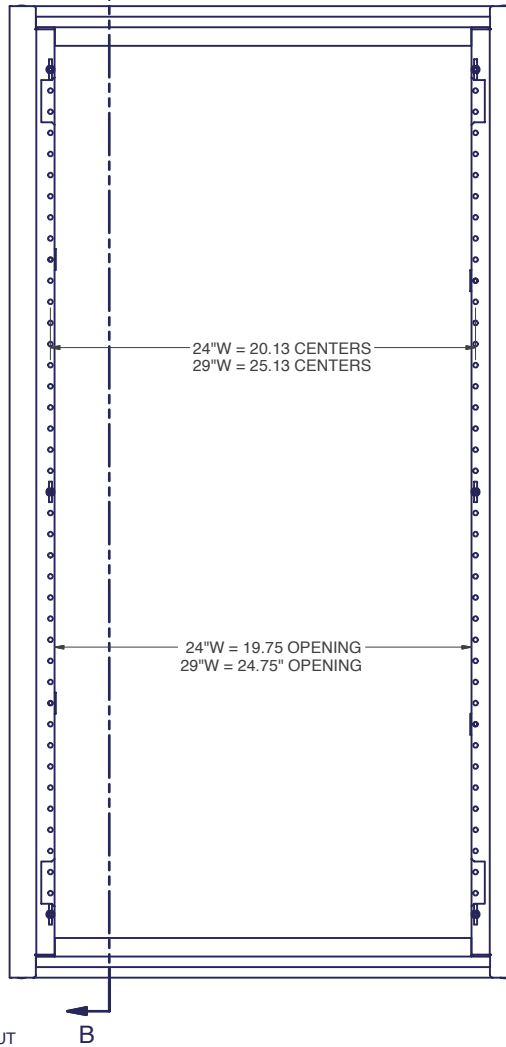

SECTION B-B

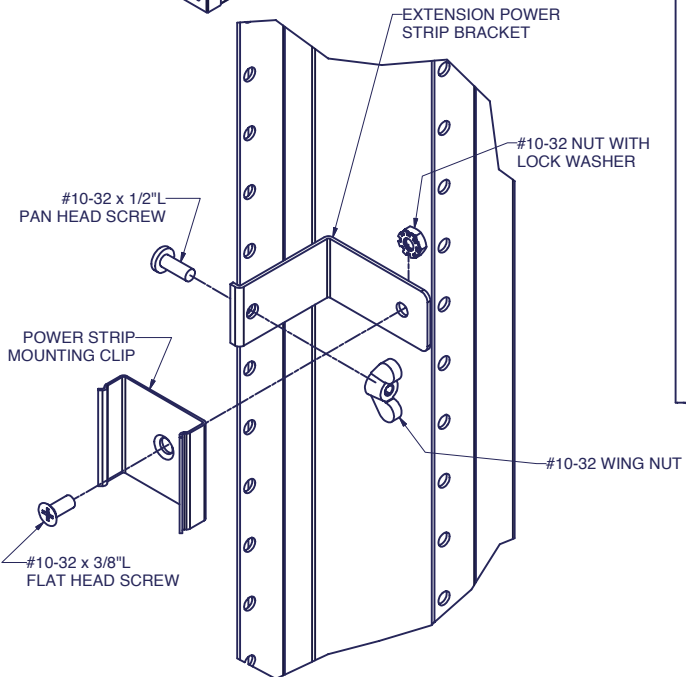
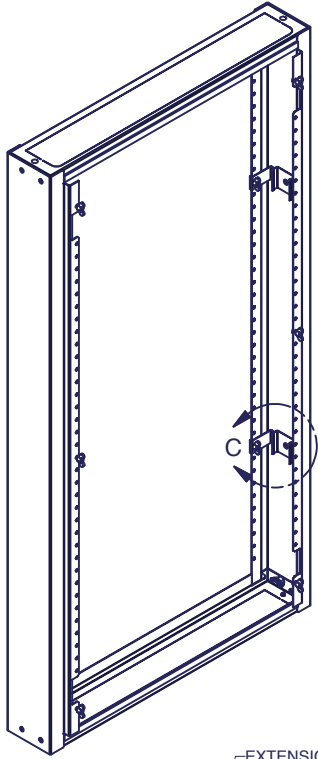
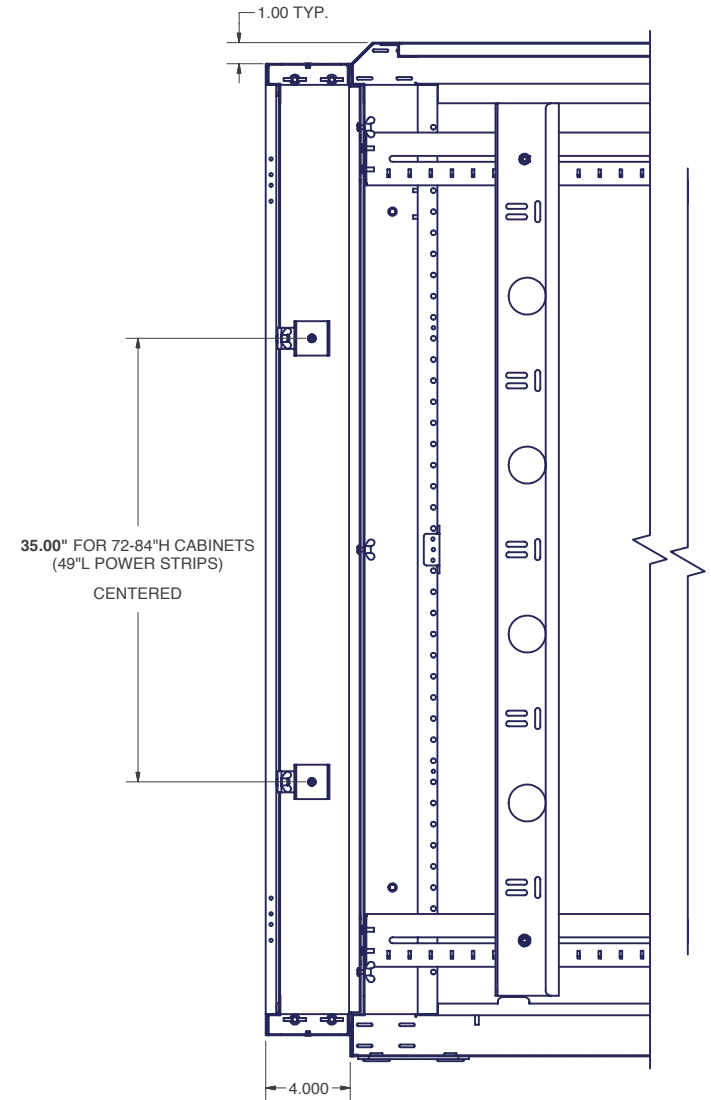

DETAIL C
TYP. 2 PER EXTENSION SIDE

INTERPRET DRAWING PER ASME Y14.5M-1994
DIMENSIONAL LIMITS APPLY AFTER APPLICATION OF FINISH
DRAWING NOT TO SCALE
TOLERANCE UNLESS OTHERWISE NOTED:
ANGULAR +/- 1-
.XXXX +/- .010
.XXX +/- .015
.XX +/- .030
.X FOR REF. ONLY

NOTICE:
Use of this document is subject to a confidentiality and nondisclosure agreement with Great Lakes Case & Cabinet Co., Inc. (GLCC) and may not be reproduced, disclosed or utilized in whole or in part without prior written authorization from GLCC.

PART NUMBER:	
QTY PER UNIT:	1
MATERIAL TYPE:	-
MATERIAL GAUGE:	-
FINISH:	-
DRAWN	DATE
CA	12/29/2003
CHECKED & APP.	DATE
WSS	10/25/2004

TITLE	
GREAT LAKES CASE & CABINET CO., INC.	
P.O. BOX 551 EDINBORO, PA 16412	
PHONE (814) 734-7303 FAX (814) 734-3907	
E-MAIL glcc@greatcabinets.com	
DWG NO:	REV
1002578	0
SHEET: 2 OF 2	



UNLESS OTHERWISE SPECIFIED ALL DIMENSIONS ARE IN INCHES