

REVISION HISTORY			
REV	DESCRIPTION	DATE	APPROVED
0	ECO-03371	10/5/2011	CDM

Bill of Material						
ITEM	PART NUMBER	STOCK NUMBER	QTY	DESCRIPTION	FILE NAME	REVISION
1	I014952		1	SOLID BOTTOM PANEL, CENTER FOR 30"W ES	I014952.ipt	0
2	I014953		1	SOLID BOTTOM PANEL, REAR, FOR 30"W x 42"D ES	I014953.ipt	0
3	XM01		83.5"	1/8" x 1/2" MAGNETIC GASKET WITH PSA	"Varies"	-
4	30063008-05004D	H31-022	2	PANEL FASTENER, TUFLOK, ITW-FASTEX. OR EQUIV.	30063008-05004D.ipt	-

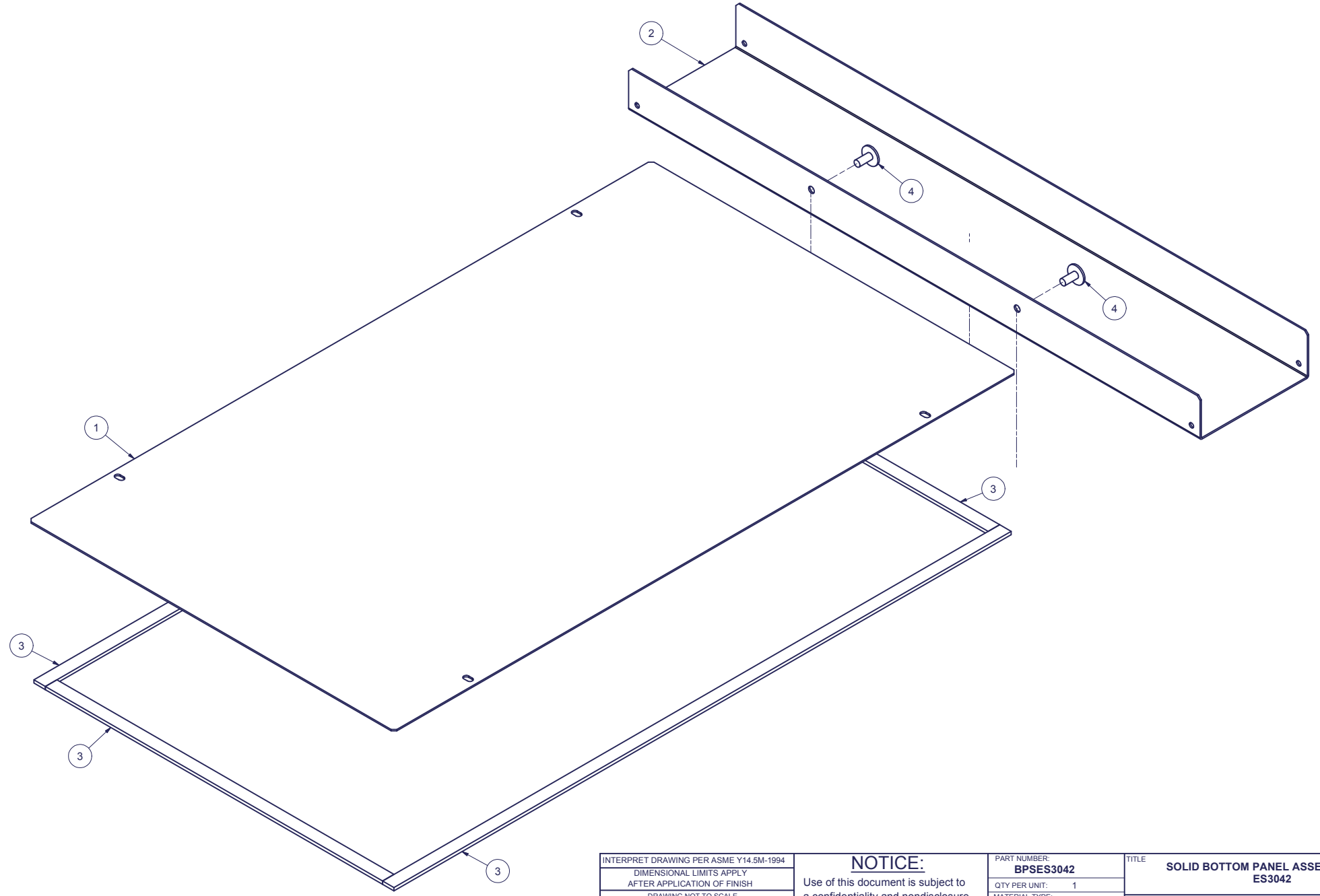
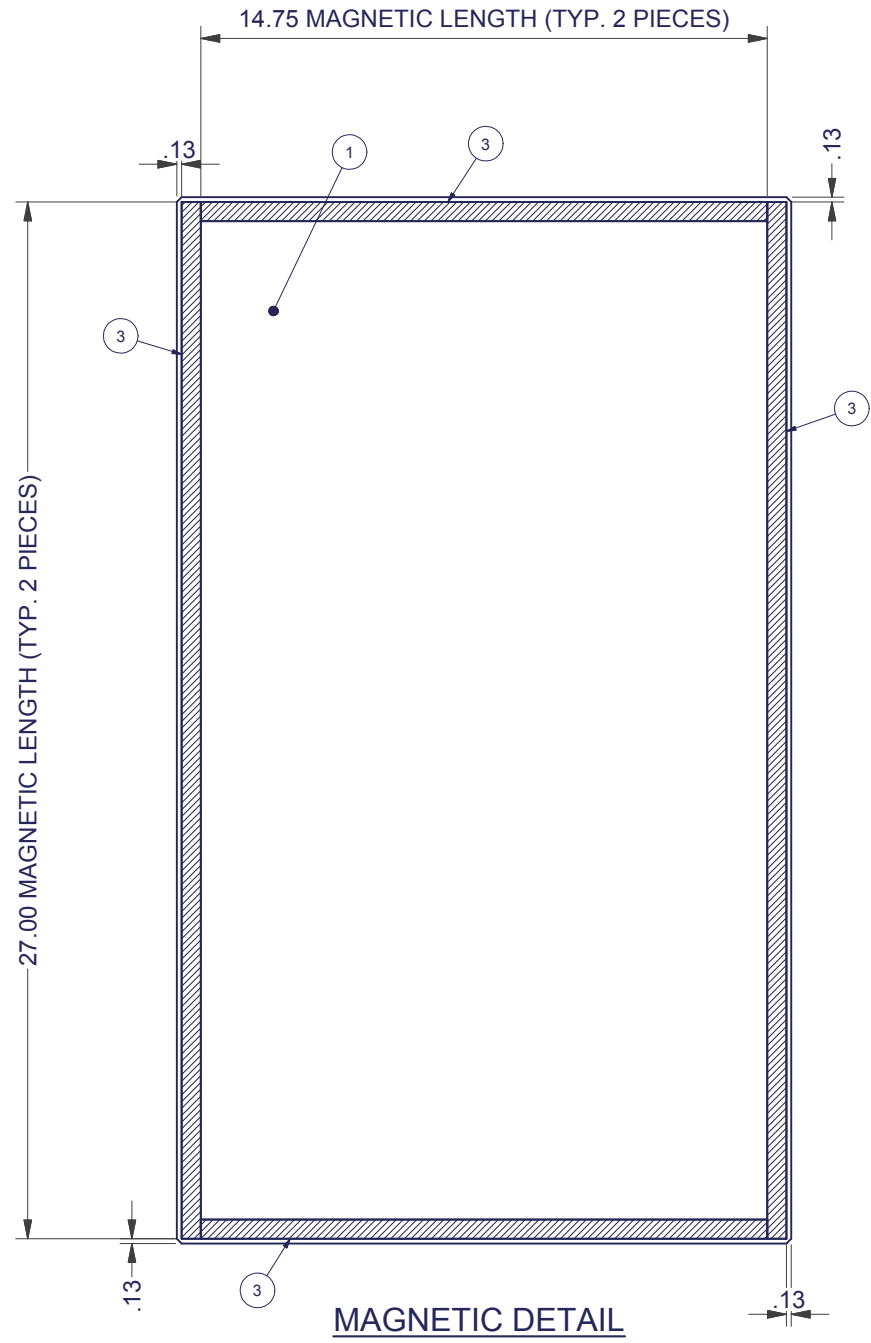

INTERPRET DRAWING PER ASME Y14.5M-1994
 DIMENSIONAL LIMITS APPLY
 AFTER APPLICATION OF FINISH
 DRAWING NOT TO SCALE
 TOLERANCE UNLESS OTHERWISE NOTED:
 ANGULAR +/- .1
 .XXXX +/- .010
 .XXX +/- .015
 .XX +/- .030
 .X FOR REF. ONLY
 UNLESS OTHERWISE SPECIFIED
 ALL DIMENSIONS ARE IN INCHES

NOTICE:
 Use of this document is subject to a confidentiality and nondisclosure agreement with Great Lakes Case & Cabinet Co., Inc. (GLCC) and may not be reproduced, disclosed or utilized in whole or in part without prior written authorization from GLCC.

PART NUMBER:
BPSES3042
 QTY PER UNIT: 1
 MATERIAL TYPE:
 CRS
 MATERIAL GAUGE:
 SEE DETAILS
 FINISH: POWDER COATED

TITLE
SOLID BOTTOM PANEL ASSEMBLY FOR ES3042
 GREAT LAKES CASE & CABINET CO., INC.
 P.O. BOX 551 EDINBORO, PA 16412
 PHONE (814) 734-7303 FAX (814) 734-3907
 E-MAIL glcc@greatcabinets.com



DRAWN DATE
 CDM 10/5/2011
 CHECKED & APP. DATE
 WSS 10/5/2011

DWG NO: **I014950**
 REV: **0**
 SHEET: 1 OF 2

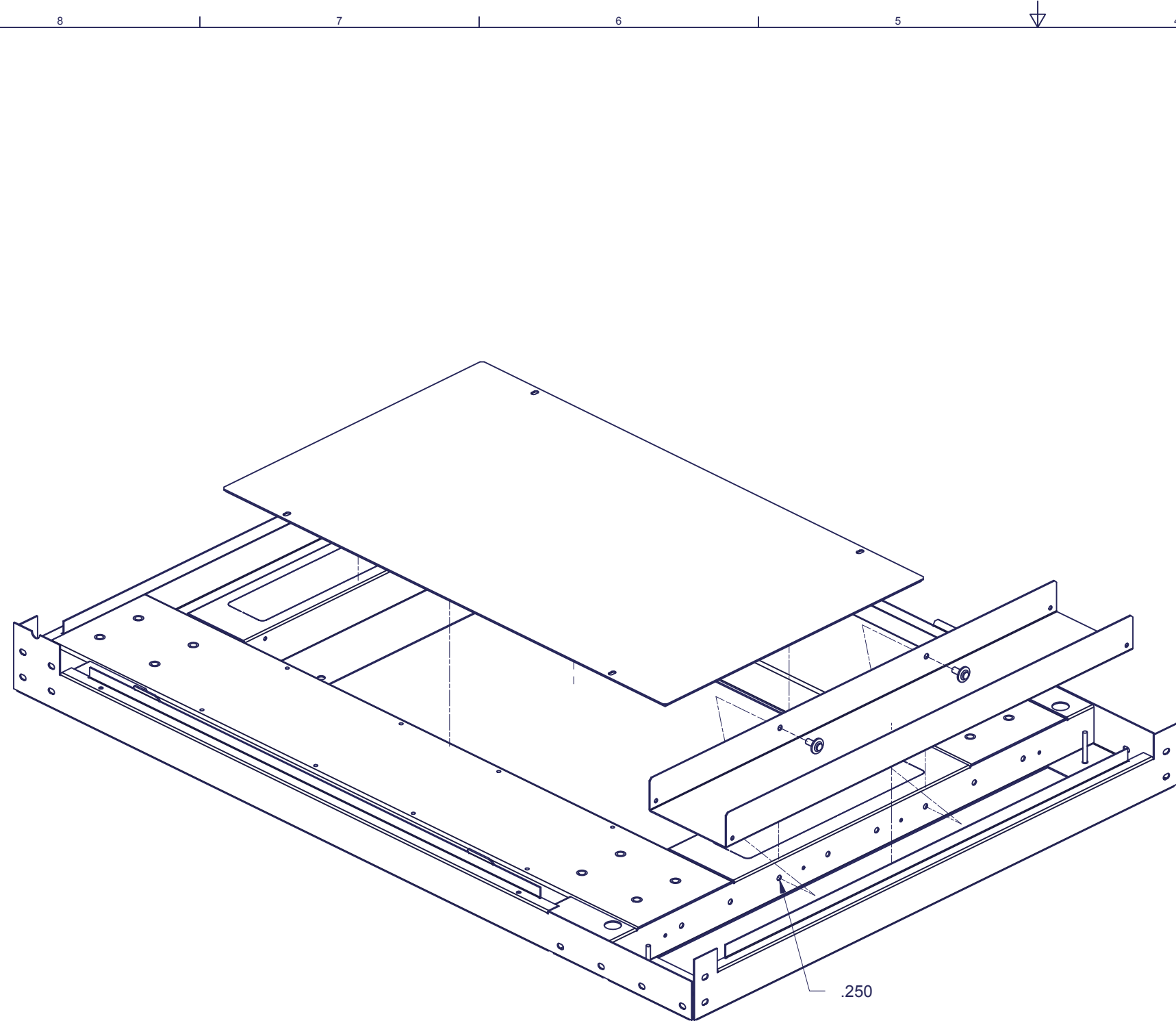

REAR

BOTTOM VIEW

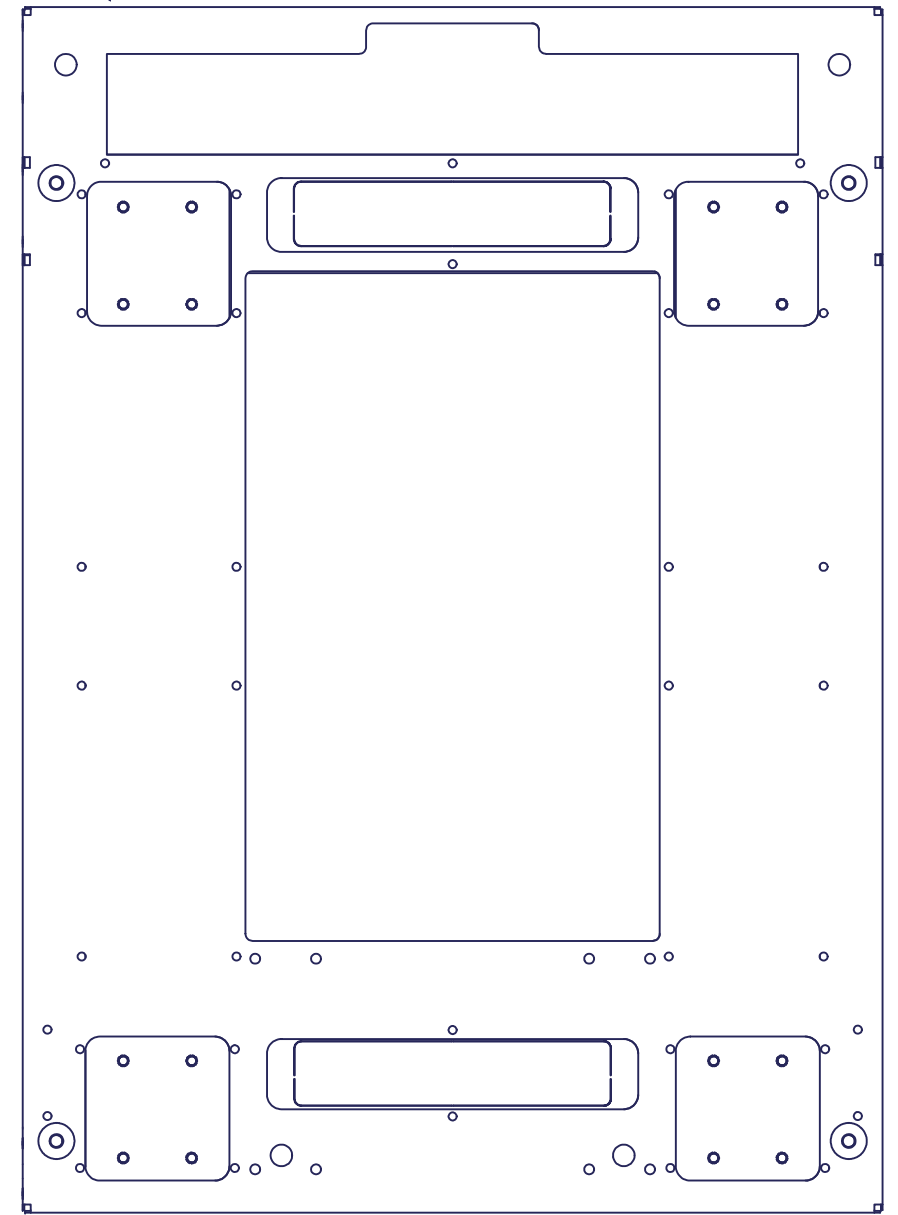

INTERPRET DRAWING PER ASME Y14.5M-1994 DIMENSIONAL LIMITS APPLY AFTER APPLICATION OF FINISH DRAWING NOT TO SCALE TOLERANCE UNLESS OTHERWISE NOTED: ANGULAR +/- 1 .XXXX +/- .010 .XXX +/- .015 .XX +/- .030 .X FOR REF. ONLY	NOTICE: Use of this document is subject to a confidentiality and nondisclosure agreement with Great Lakes Case & Cabinet Co., Inc. (GLCC) and may not be reproduced, disclosed or utilized in whole or in part without prior written authorization from GLCC.	PART NUMBER: BPSES3042	TITLE SOLID BOTTOM PANEL ASSEMBLY FOR ES3042		
		QTY PER UNIT: 1	GREAT LAKES CASE & CABINET CO., INC. P.O. BOX 551 EDINBORO, PA 16412 PHONE (814) 734-7303 FAX (814) 734-3907 E-MAIL glcc@greatcabinets.com		
		MATERIAL TYPE: CRS	MATERIAL GAUGE: SEE DETAILS		
		FINISH: POWDER COATED	DRAWN CDM	DATE 10/5/2011	DWG NO: 1014950
THIRD ANGLE PROJECTION	UNLESS OTHERWISE SPECIFIED ALL DIMENSIONS ARE IN INCHES	CHECKED & APP. WSS	DATE 10/5/2011	REV 0	SHEET: 2 OF 2