

REVISION HISTORY			
REV	DESCRIPTION	DATE	APPROVED
0	-	7/22/2002	SB
1	ECO-00193	3/10/2000	WSS
2	ECO-00569	-	JFW
3	ECO-01077	6/11/2002	SB
4	ECO-02683	10/9/2009	FED

Bill of Material						
ITEM	PART NUMBER	STOCK NUMBER	QTY	DESCRIPTION	FILE NAME	REVISION
1			1	BOTTOM PANEL, SOLID, FOR E CABINETS	I000491.ipt	1
2	GASKET1/2		4'-8"	1/8" X 1/2" NEOPRENE GASKET W/ PSA		-

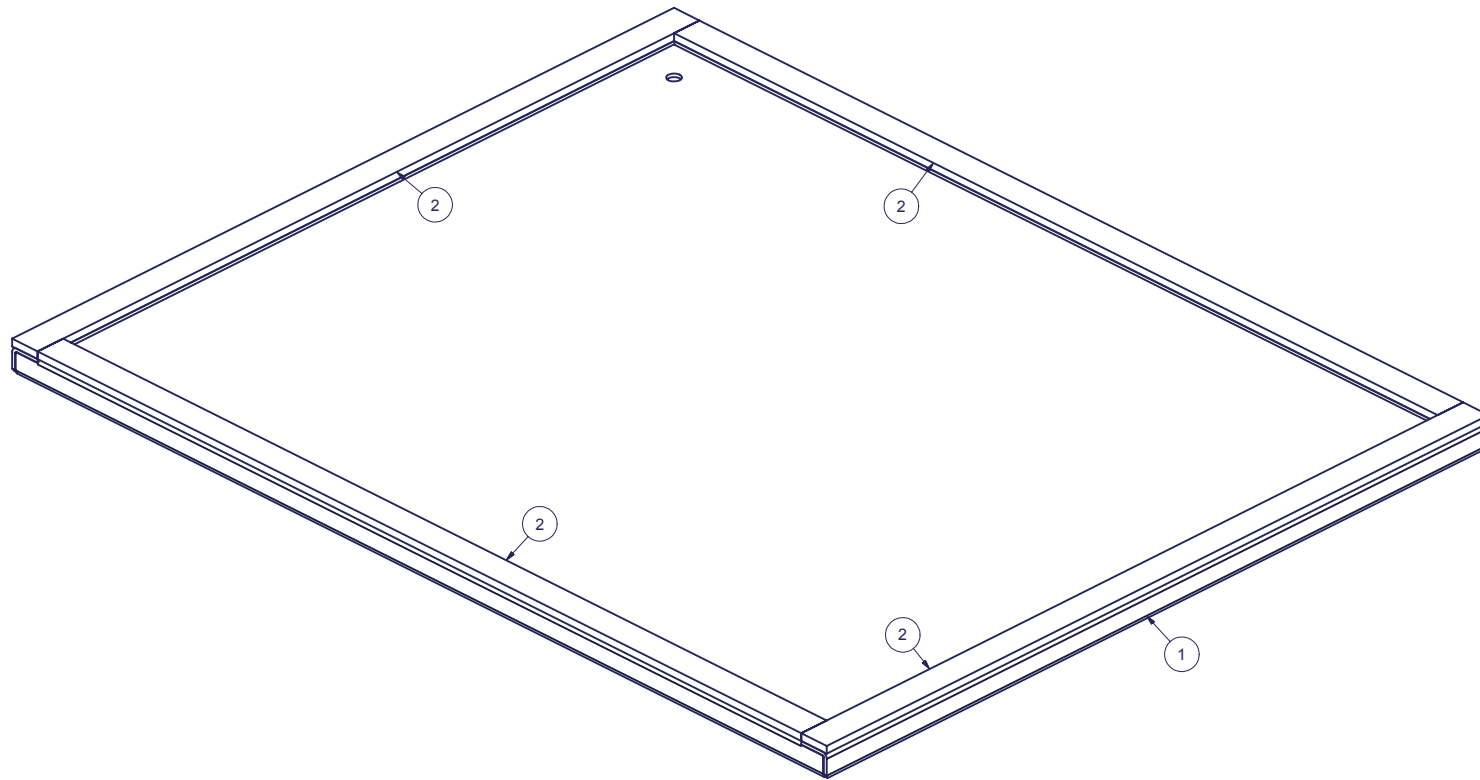

NOTE:  
For use with GL300E, GL480E, and GL600E Enclosure

INTERPRET DRAWING PER ASME Y14.5M-1994
DIMENSIONAL LIMITS APPLY AFTER APPLICATION OF FINISH
DRAWING NOT TO SCALE
TOLERANCE UNLESS OTHERWISE NOTED:
ANGULAR +/- 1-
.XXXX +/- .010
.XXX +/- .015
.XX +/- .030
.X FOR REF. ONLY
UNLESS OTHERWISE SPECIFIED ALL DIMENSIONS ARE IN INCHES

**NOTICE:**  
Use of this document is subject to a confidentiality and nondisclosure agreement with Great Lakes Case & Cabinet Co., Inc. (GLCC) and may not be reproduced, disclosed or utilized in whole or in part without prior written authorization from GLCC.

PART NUMBER: BPES
QTY PER UNIT: 1
MATERIAL TYPE: N/A
MATERIAL GAUGE: #16 GA
FINISH: N/A
DRAWN SB
CHECKED 7-22-02

TITLE <b>BOTTOM PANEL, SOLID FOR E CABINETS, ASSEMBLY</b>		
GREAT LAKES CASE & CABINET CO., INC. P.O. BOX 551 EDINBORO, PA 16412 PHONE (814) 734-7303 FAX (814) 734-3907 E-MAIL glcc@greatcabinets.com		
DWG NO: I000490	REV 4	SHEET 1 OF 1

REVISION HISTORY			
REV	DESCRIPTION	DATE	APPROVED
0	ECO-01077	7/22/2002	SB
1	ECO-02683	10/9/2009	FED

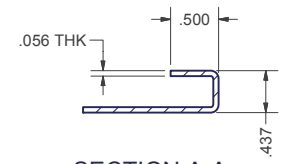
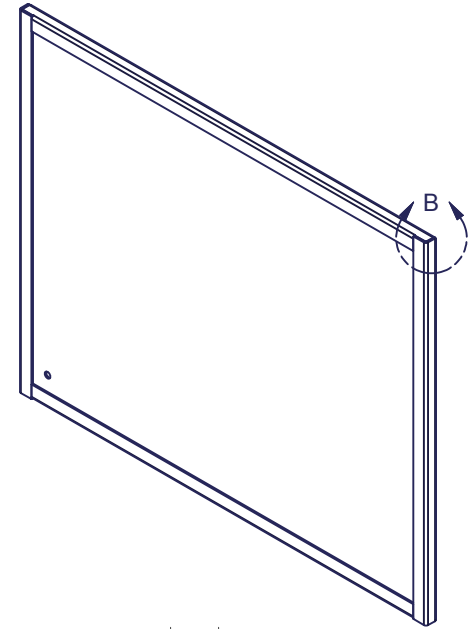
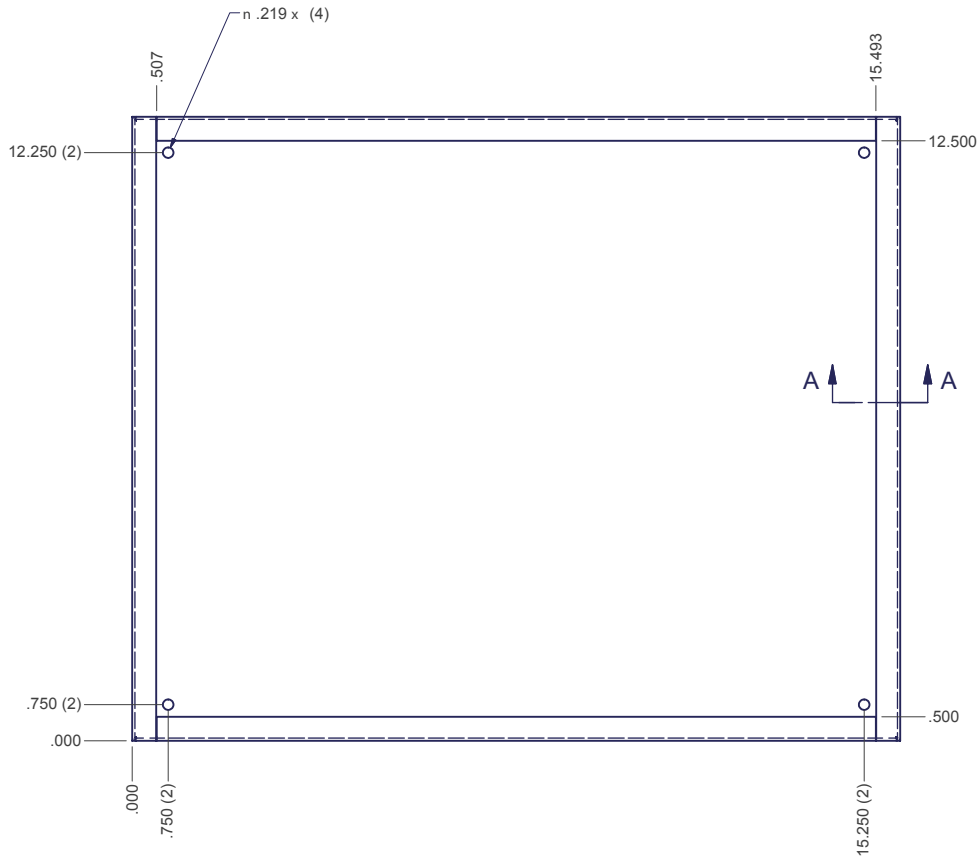
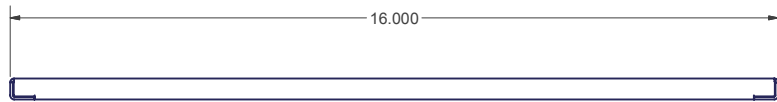

**SECTION A-A**  
TYP (4) SIDES

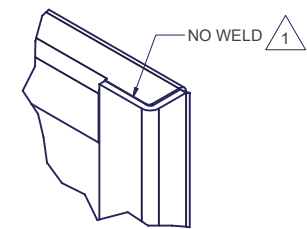

**DETAIL B**  
TYP (4) CORNERS

INTERPRET DRAWING PER ASME Y14.5M-1994
DIMENSIONAL LIMITS APPLY AFTER APPLICATION OF FINISH
DRAWING NOT TO SCALE
TOLERANCE UNLESS OTHERWISE NOTED:
ANGULAR +/- 1-
.XXXX +/- .010
.XXX +/- .015
.XX +/- .030
.X FOR REF. ONLY
UNLESS OTHERWISE SPECIFIED ALL DIMENSIONS ARE IN INCHES

**NOTICE:**  
Use of this document is subject to a confidentiality and nondisclosure agreement with Great Lakes Case & Cabinet Co., Inc. (GLCC) and may not be reproduced, disclosed or utilized in whole or in part without prior written authorization from GLCC.

PART NUMBER:	
QTY PER UNIT:	1
MATERIAL TYPE:	CRS
MATERIAL GAUGE:	#16 GA
FINISH:	SEE NOTES
DRAWN:	FED 10/9/2009
CHECKED:	WSS 10/9/2009

TITLE		
<b>BOTTOM PANEL, SOLID, FOR E CABINETS</b>		
GREAT LAKES CASE & CABINET CO., INC.		
P.O. BOX 551 EDINBORO, PA 16412		
PHONE (814) 734-7303 FAX (814) 734-3907		
E-MAIL glcc@greatcabinets.com		
DWG NO:	REV	SHEET 1 OF 1
I000491	1	