

| REVISION HISTORY |             |            |          |
|------------------|-------------|------------|----------|
| REV              | DESCRIPTION | DATE       | APPROVED |
| 0                | ECO-01341   | 10/25/2004 | WSS      |

| Bill of Material |              |     |   |                 |     |
|------------------|--------------|-----|---|-----------------|-----|
| ITEM             | PART NUMBER  | QTY | DESCRIPTION                                       | FILE NAME       | REV |
| 1                | EXT429TBX200 | 1   | 4"D EXTENSION, 29"W, TOP & BOTTOM PACKAGED KIT.   | I001927-kit.iam | 0   |
| 2                | EXT484SX200  | 1   | 4" D EXTENSION, 84"H, SIDE CHANNELS, PACKAGED KIT | I001928-kit.iam | 0   |

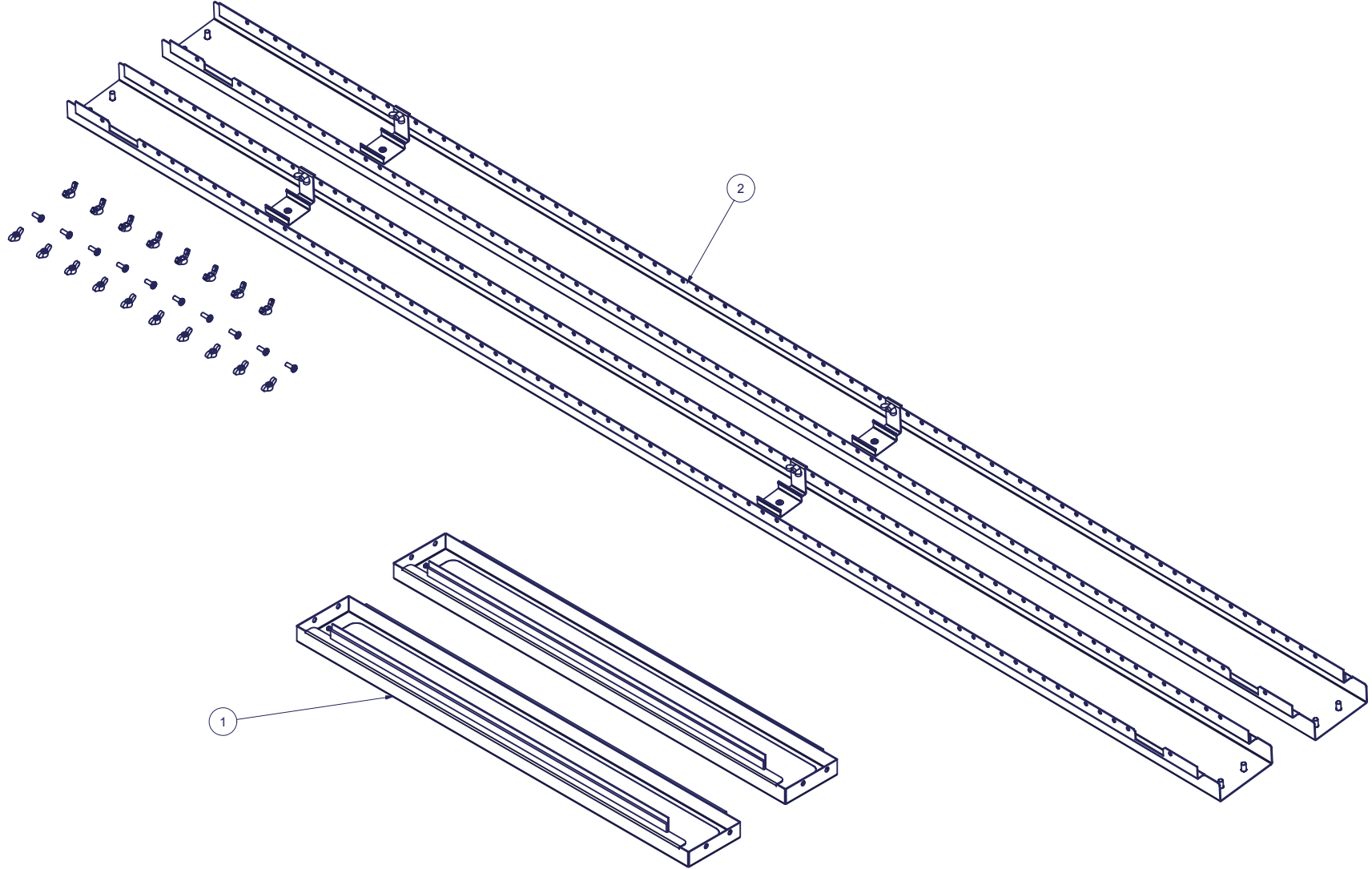

INTERPRET DRAWING PER ASME Y14.5M-1994  
 DIMENSIONAL LIMITS APPLY  
 AFTER APPLICATION OF FINISH  
 DRAWING NOT TO SCALE  
 TOLERANCE UNLESS OTHERWISE NOTED:  
 ANGULAR +/- 1°  
 .XXXX +/- .010  
 .XXX +/- .015  
 .XX +/- .030  
 X FOR REF. ONLY

**NOTICE:**  
 Use of this document is subject to a confidentiality and nondisclosure agreement with Great Lakes Case & Cabinet Co., Inc. (GLCC) and may not be reproduced, disclosed or utilized in whole or in part without prior written authorization from GLCC.

PART NUMBER:  
**84E29EXT**  
 QTY PER UNIT: 1  
 MATERIAL TYPE: -  
 MATERIAL GAUGE:  
**#16 GA**  
 FINISH: -  
 DRAWN DATE: 3/22/2005  
 WSS  
 CHECKED & APP. DATE: 10/25/2004  
 WSS

TITLE  
**4" DEEP ENCLOSURE EXTENSION, ENHANCED, 84"H x 29"W , 2 BOX KIT.**  
 GREAT LAKES CASE & CABINET CO., INC.  
 P.O. BOX 551 EDINBORO, PA 16412  
 PHONE (814) 734-7303 FAX (814) 734-3907  
 E-MAIL glcc@greatcabinets.com



THIRD ANGLE PROJECTION  
 UNLESS OTHERWISE SPECIFIED  
 ALL DIMENSIONS ARE IN INCHES

DWG NO: **1001926** REV: **0** SHEET: 1 OF 2

# ASSEMBLED VIEW

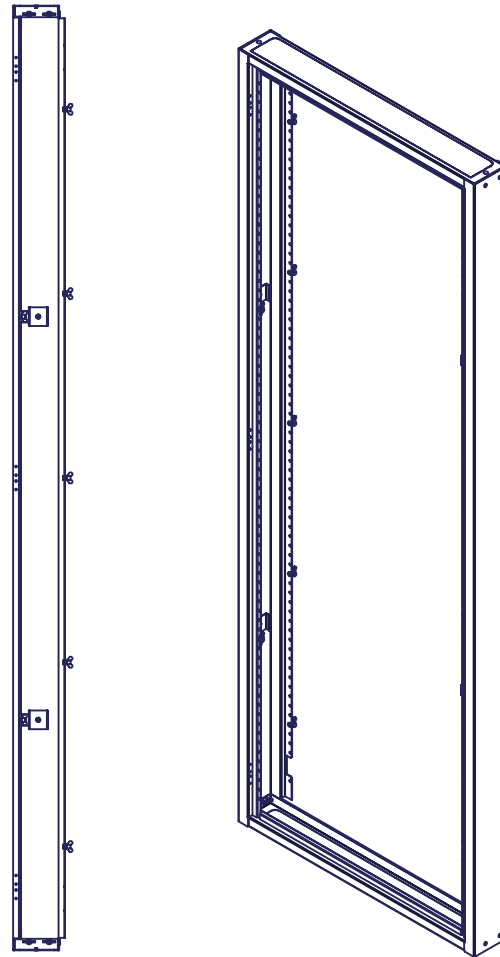
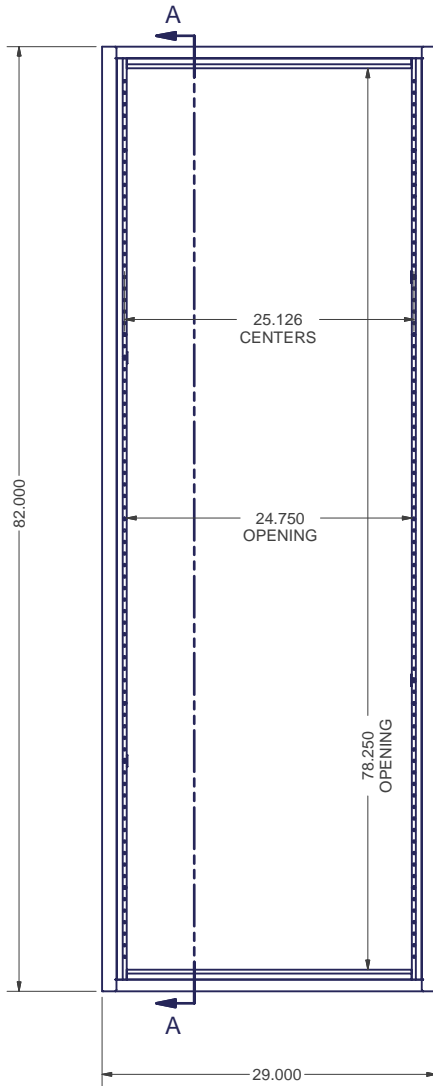

CABINET FRAME SHOWN FOR REFERENCE ONLY

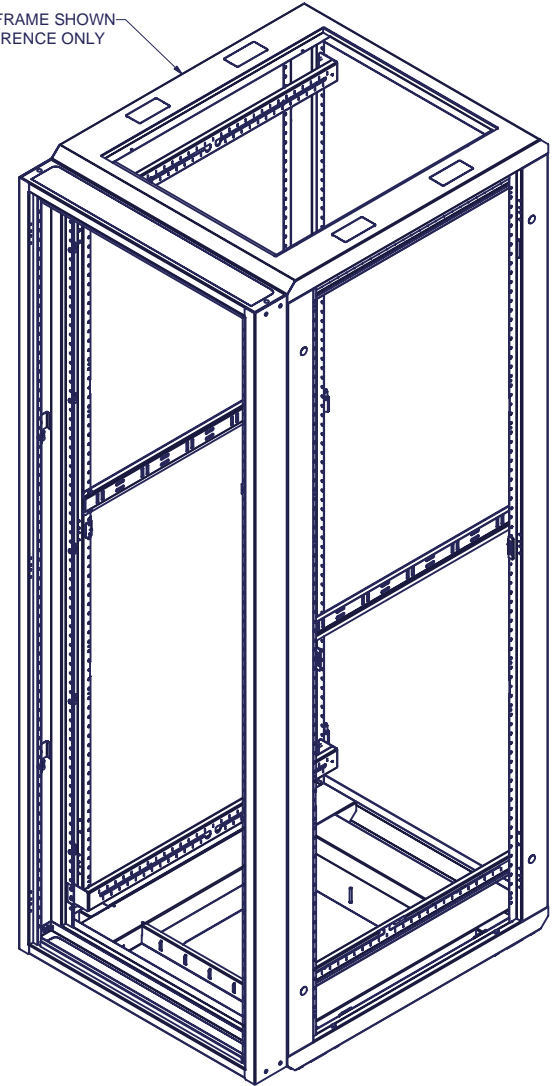

SECTION A-A

INTERPRET DRAWING PER ASME Y14.5M-1994  
 DIMENSIONAL LIMITS APPLY  
 AFTER APPLICATION OF FINISH  
 DRAWING NOT TO SCALE  
 TOLERANCE UNLESS OTHERWISE NOTED:  
 ANGULAR +/- 1'  
 .XXXX +/- .010  
 .XXX +/- .015  
 .XX +/- .030  
 .X FOR REF. ONLY

### NOTICE:

Use of this document is subject to a confidentiality and nondisclosure agreement with Great Lakes Case & Cabinet Co., Inc. (GLCC) and may not be reproduced, disclosed or utilized in whole or in part without prior written authorization from GLCC.

PART NUMBER:  
**84E29EXT4X200**  
 QTY PER UNIT: 1  
 MATERIAL TYPE: -  
 MATERIAL GAUGE: -  
 FINISH: -  
 DRAWN: CA DATE: 12/30/2003  
 CHECKED & APP. DATE: WSS 10/25/2004

TITLE  
**4"D EXTENSION FOR 840E-29 CABINETS**  
**GREAT LAKES CASE & CABINET CO., INC.**  
 P.O. BOX 551 EDINBORO, PA 16412  
 PHONE (814) 734-7303 FAX (814) 734-3907  
 E-MAIL glcc@greatcabinets.com

DWG NO: 1001926  
 REV: 0  
 SHEET: 2 OF 2



THIRD ANGLE PROJECTION

UNLESS OTHERWISE SPECIFIED  
 ALL DIMENSIONS ARE IN INCHES