

REVISION HISTORY			
REV	DESCRIPTION	DATE	APPROVED
1	ECO-01131	8/22/2002	WSS
1	ECO-02701	10/27/2009	FED

Bill of Material						
ITEM	PART NUMBER	STOCK NUMBER	QTY	DESCRIPTION	FILE NAME	REVISION
1	-	-	1	HORIZONTAL LACING BAR FOR 32"D E CABINETS	I000686.ipt	1
2	SCR1032X12BLK	H01-078	2	#10-32 x 1/2" PAN HEAD PHIL TYPE 23 - BLACK	SCR1032X500BLK.ipt	-

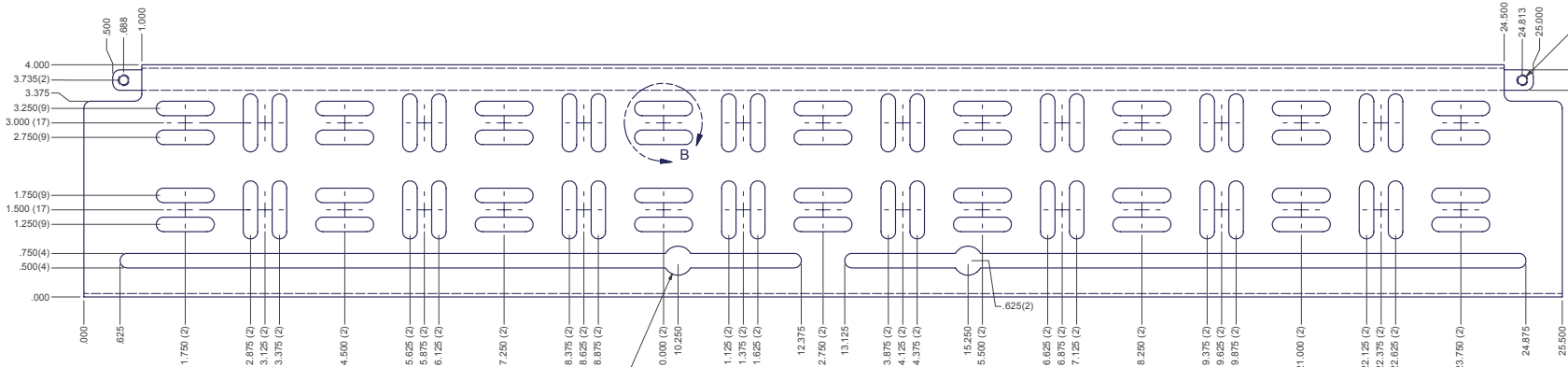
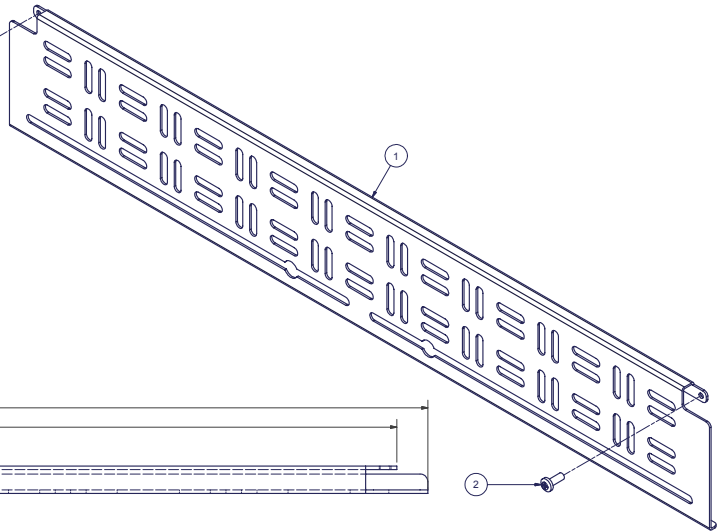
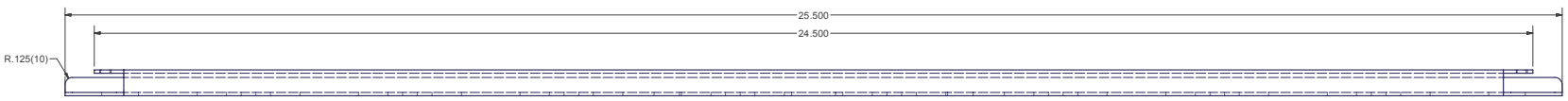
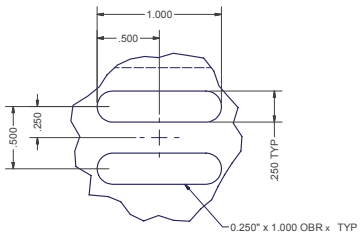
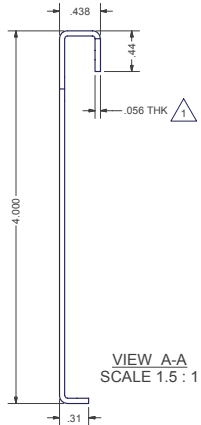

SPECIAL NOTES:

1. FINISH PER TD-09-103 (POWDER COAT) CLASS B, TEXTURE LEVEL 3 - ALL SURFACES UNLESS OTHERWISE NOTED.
2. DIMENSIONS APPLY AFTER APPLICATION OF FINISH.
3. TYPICAL BEND = R.030" x 90° INSIDE.

INTERPRET DRAWING PER ASME Y14.5M-1994
DIMENSIONAL LIMITS APPLY AFTER APPLICATION OF FINISH
DRAWING NOT TO SCALE
TOLERANCE UNLESS OTHERWISE NOTED: ANGULAR +/- 1° XXX +/- .010 XXX +/- .015 XXX +/- .030 X FOR REF. ONLY
UNLESS OTHERWISE SPECIFIED ALL DIMENSIONS ARE IN INCHES

NOTICE:
Use of this document is subject to a confidentiality and nondisclosure agreement with Great Lakes Case & Cabinet Co., Inc. (GLCC) and may not be reproduced, disclosed or utilized in whole or in part without prior written authorization from GLCC.

PART NUMBER: HLB32	TITLE: HORIZONTAL LACING BAR FOR 32"D E CABINETS
QTY PER UNIT: 1	MATERIAL TYPE: CRS
MATERIAL GRADE: HL GA	FINISH: SEE NOTES
DRAWN: JAL	DATE: 3/4/2003
CHECKED & APP: CA	DATE: 3-4-03
DWG NO: I000686	REV: 1
SHEET: 1 OF 1	

