

REVISION HISTORY			
REV	DESCRIPTION	DATE	APPROVED
0	ECO-01292	8/28/2003	WSS
1	ECO-02616	8/5/2009	FED

Bill of Material						
ITEM	PART NUMBER	STOCK NUMBER	QTY	DESCRIPTION	FILE NAME	REV
1	-	-	1	60"H x 24"W PERIMETER VENTER DOOR - ECONOMY ENAHNCED	I001652.iam	1
2	XHGLCC	H19-067	1	GLCC SWING HANDLE	XHGLCC NO CAM.iam	-
3	HINGEF	H20-023	2	HINGE - FEMALE	I000535.ipt	1
4	SCR1032X500FHBLK23	H01-156	4	SCREW, 10-32x1/2" PH FLAT TYPE 23 BLACK OXIDE/WAX RoHS	SCR1032X500FHBLK23.ipt	-
5	AA57711001	H17-005	1	SINGLE POINT CAM FOR XHGLCC	AA5771100.ipt	-

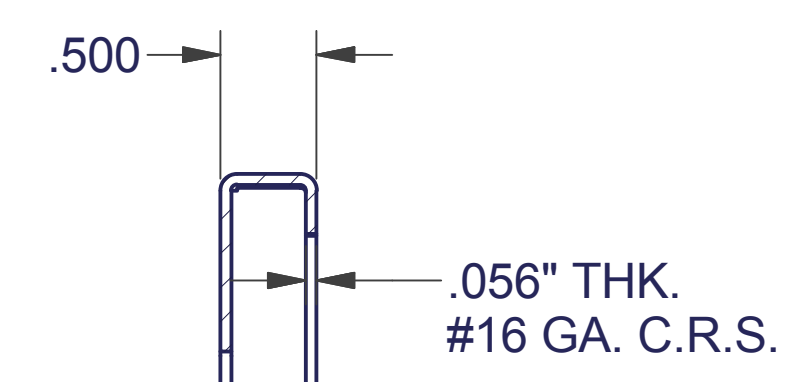

SECTION A-A
SCALE 1

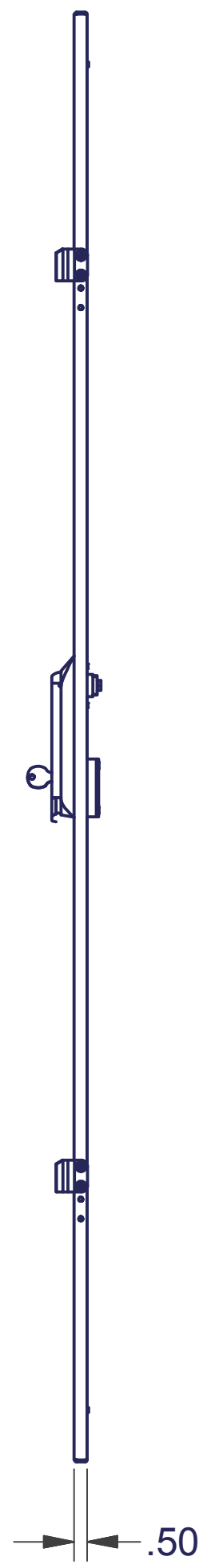
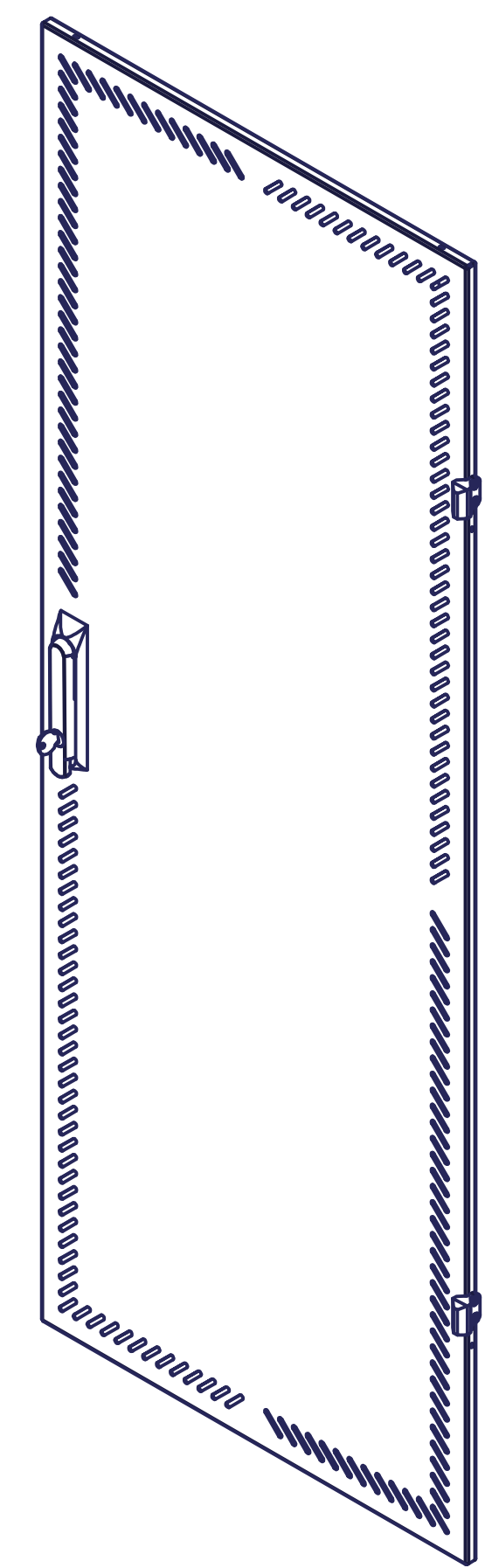
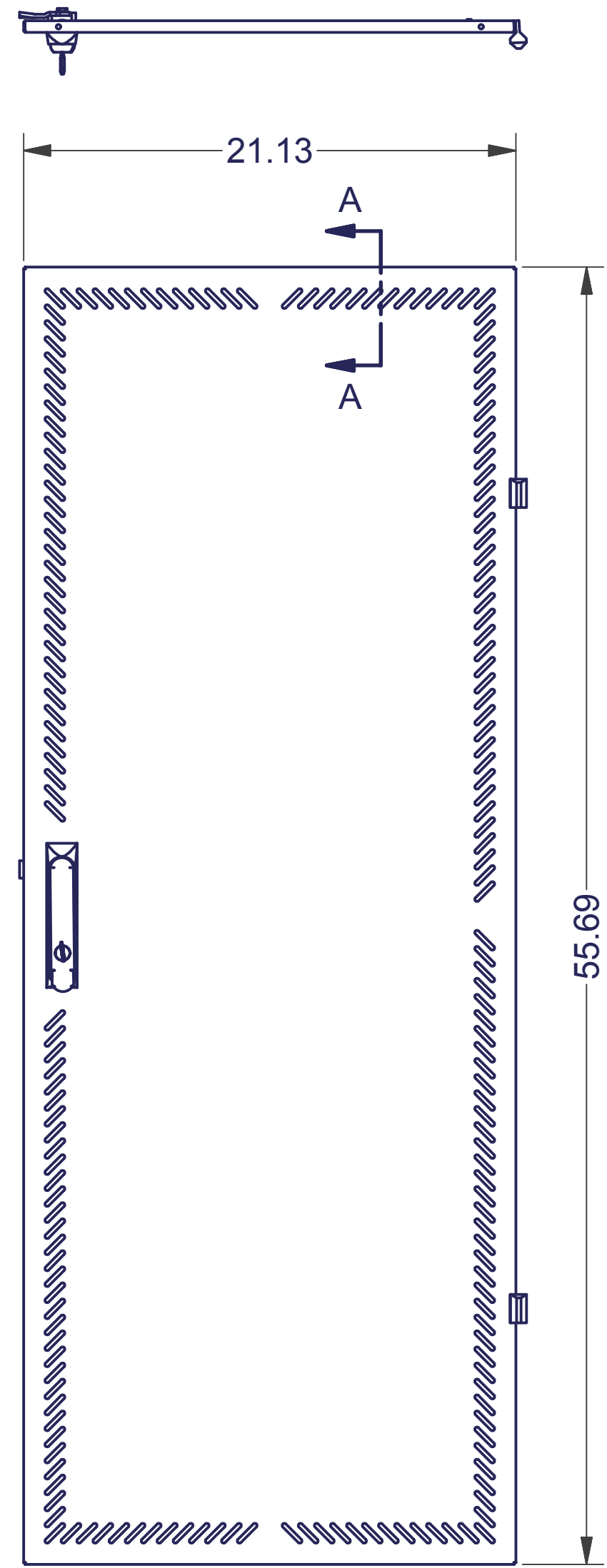
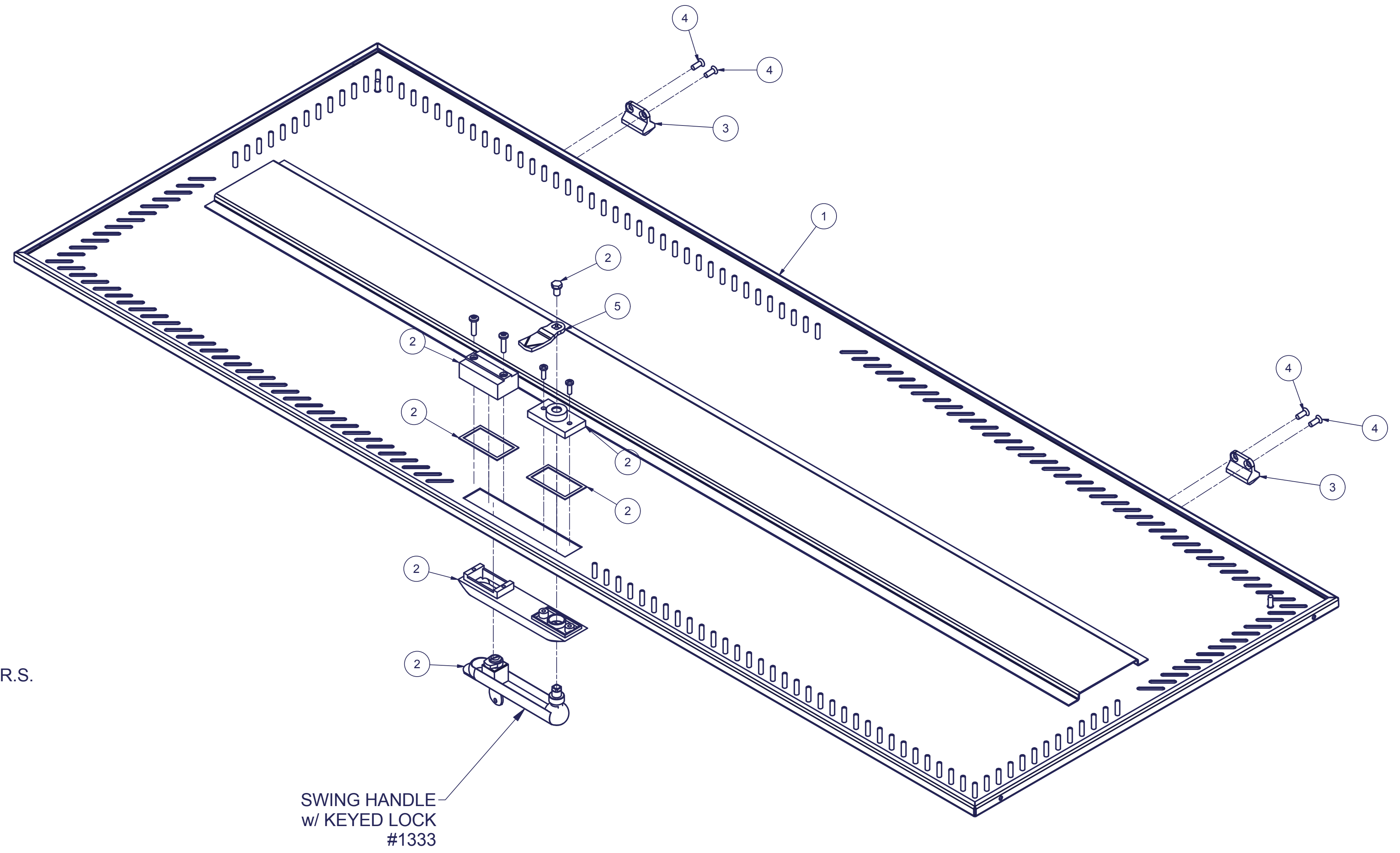

SWING HANDLE
w/ KEYED LOCK
#1333

INTERPRET DRAWING PER ASME Y14.5M-1994
DIMENSIONAL LIMITS APPLY
AFTER APPLICATION OF FINISH
DRAWING NOT TO SCALE
TOLERANCE UNLESS OTHERWISE NOTED:
ANGULAR +/- 1'
.XXXX +/- .010
.XXX +/- .015
.XX +/- .030
.X FOR REF. ONLY
UNLESS OTHERWISE SPECIFIED
ALL DIMENSIONS ARE IN INCHES

NOTICE:
Use of this document is subject to a confidentiality and nondisclosure agreement with Great Lakes Case & Cabinet Co., Inc. (GLCC) and may not be reproduced, disclosed or utilized in whole or in part without prior written authorization from GLCC.

PART NUMBER:
6004E24X100
QTY PER UNIT: 1
MATERIAL TYPE: CRS
MATERIAL GAUGE:
FINISH: -
DRAWN: WSS DATE: 8/28/2003
CHECKED & APP. DATE: 8/28/03
C.A.

TITLE: **60"H X 24"W PERIMETER VENTED DOOR - TOP LEVEL ASSEMBLY**
GREAT LAKES CASE & CABINET CO., INC.
P.O. BOX 551 EDINBORO, PA 16412
PHONE (814) 734-7303 FAX (814) 734-3907
E-MAIL glcc@greatcabinets.com
DWG NO: **1001651**
REV: **1**
SHEET: 1 OF 1