

CONFIG PART #	
840ENT4048SSSS-NS	840EN4048SSSS-NS
EN FRAME 84"H x 40"W x 48"D WITH 2 PAIR OF 45 RMU #12-24 TAPPED RAILS, CABLE MANAGEMENT FINGERS ON ALL RAILS, SOLID TOP, DUAL HINGE PERF FRONT DOOR AND SPLIT PERF REAR DOOR	EN FRAME 84"H x 40"W x 48"D WITH 2 PAIR OF 45 RMU M6 RAILS, CABLE MANAGEMENT FINGERS ON ALL RAILS, SOLID TOP, DUAL HINGE PERF FRONT DOOR AND SPLIT PERF REAR DOOR

19" EIA 310-E COMPLIANT
REF. PART # FOR:
#12-24 TAPPED EQUIP. MTG. HOLES
-OR-
3/8" SQUARE EQUIP. MTG. HOLES
W/ M6 HARDWARE

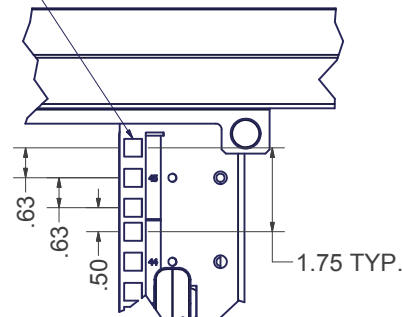

DETAIL C

LEVELER MTG. HOLES

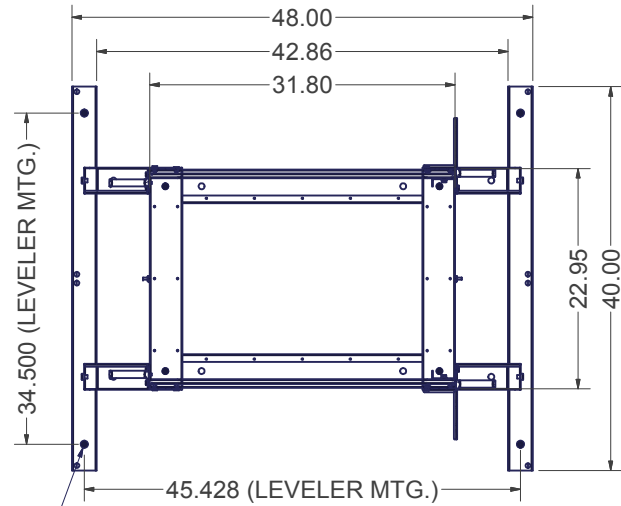

SECTION B-B
DOORS AND SIDES REMOVED

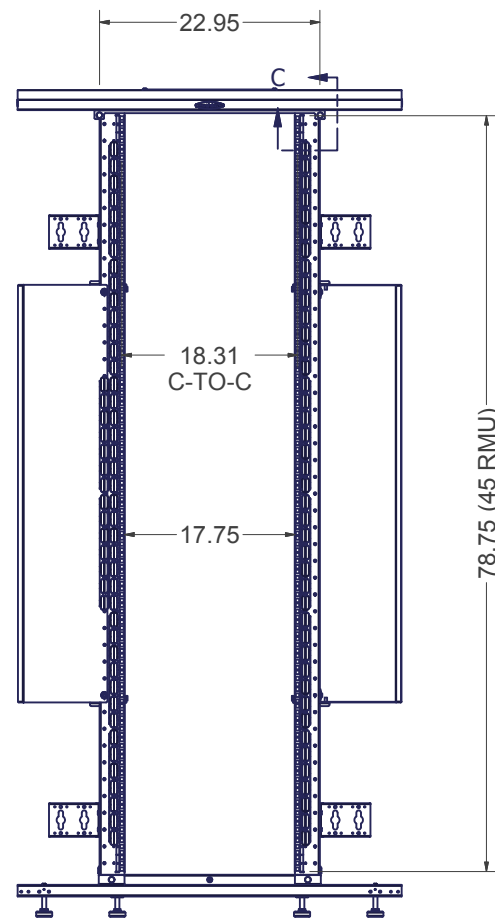

FRONT VIEW
DOORS AND SIDES REMOVED

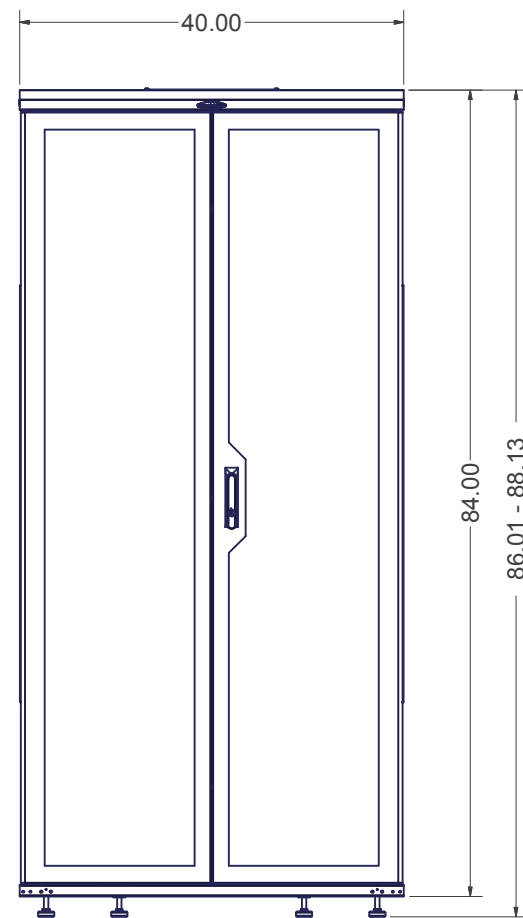

FRONT VIEW

LEVELING GLIDES (8 INCLUDED)
1/2-13 UNC THREADED HOLES

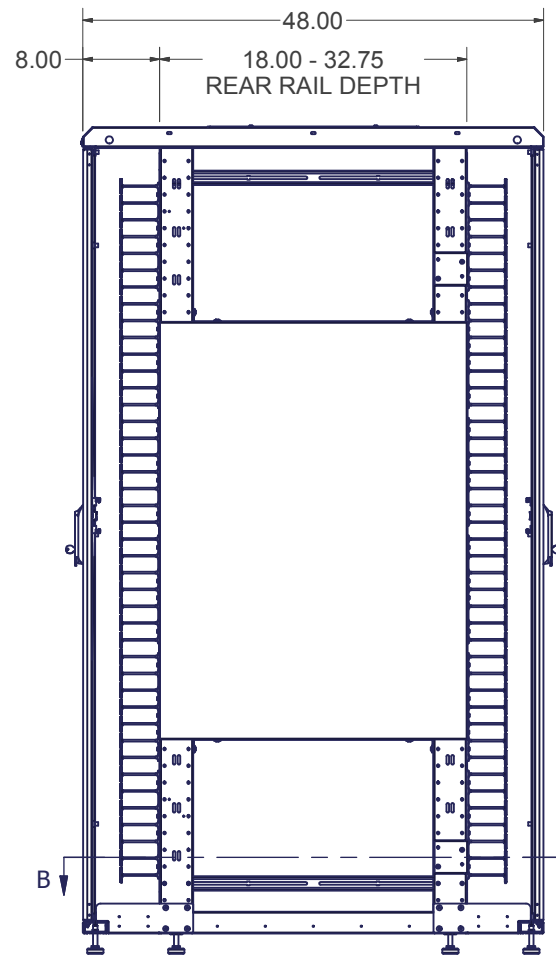

RIGHT SIDE VIEW

INDEPENDENT MOUNTING LOCATIONS
FOR LADDERRACK BRACKETS OR
TOP MOUNTED CABLE TROUGHS

6.63 x 27.00 CABLE PASS
THROUGH KNOCKOUT
(178.88 sq.in.), 2 PLACES

TOP PANEL OPENING
(273 sq.in.); SOLID,
VENTED, OR WITH
EXHAUST FANS
UP TO 1100 CFM.

5.75 x 17.25 CABLE PASS
THROUGH KNOCKOUT
(99.19 sq.in.), 2 PLACES

6.63 x 7.25 CABLE PASS
THROUGH KNOCKOUT
(48.03 sq.in.), 4 PLACES

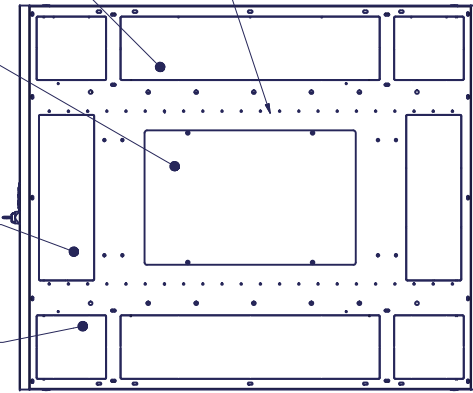

TOP VIEW

SPLIT MESH DOORS
FRONT AND REAR
PART # 8402EN40SM

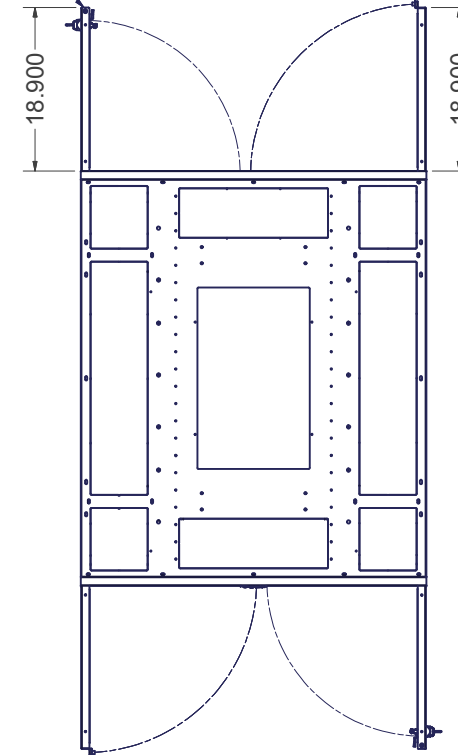

TOP VIEW

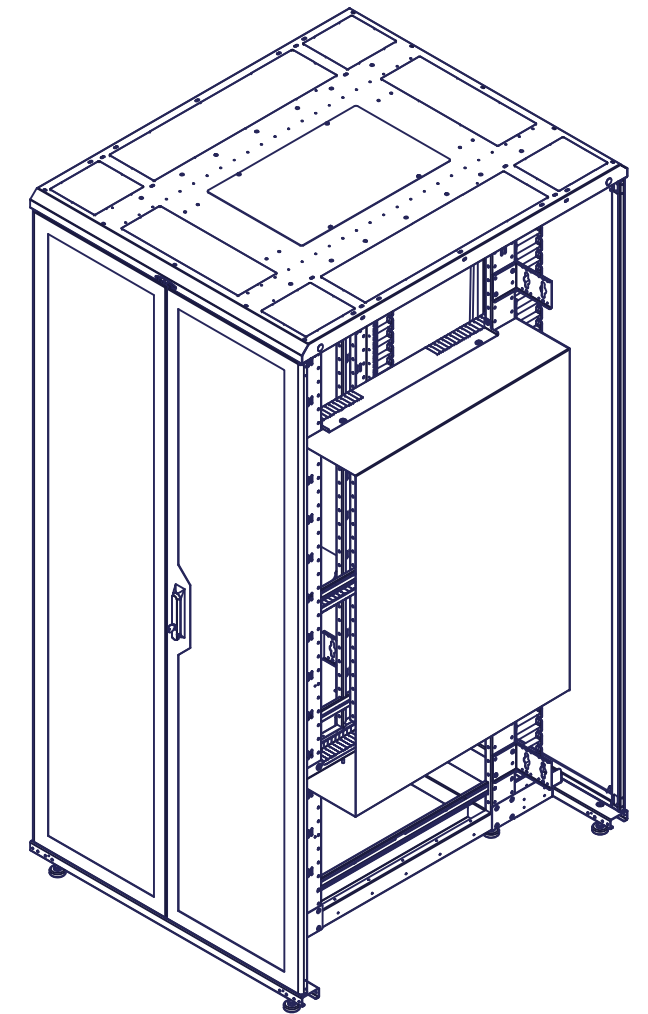

SPECIFICATIONS:

CONFIG. # KIT INCLUDES: QTY. 1 8401ENX4048, BASE FRAME UNIT WITH RAILS
QTY. 2 8402EN40SM, SPLIT MESH FRONT/REAR DOOR ASSEMBLY
QTY. 1 8402EN40SM, EN SIDE AIRFLOW BAFFLE CISCO 7018 SWITCH

DIMENSIONS: 84.0"H x 40.0"W x 48.0"D

RACK SPACES: 45 RMU w/ NUMBERED RMU INDICATORS, 19" EIA 310-E COMPLIANT.

COLOR: DURABLE TEXTURED BLACK POWDER COATING

CONSTRUCTION: FULL WELDED FRAME WITH RECESSED #12 GA CORNER POSTS
1 PAIR FIXED #12 GA RAILS, 1 PAIR ADJUSTABLE DEPTH #12 GA RAILS
DOORS #16 C.R.S. & LIGHTWEIGHT ALUMINUM SIDE AIRFLOW BAFFLE
KIT FOR 25 RMU 7018 CISCO SWITCH

HARDWARE: PACKAGE OF QTY-50; #12-24 SCREWS -OR- M6 SCREWS W/ CAGE NUTS, INCLUDED.

INTERPRET DRAWING PER ASME Y14.5M-1994
DIMENSIONAL LIMITS APPLY AFTER APPLICATION OF FINISH
DRAWING NOT TO SCALE
TOLERANCE UNLESS OTHERWISE NOTED:
ANGULAR +/- 1
.XXXX +/- .010
.XXX +/- .015
.XX +/- .030
.X FOR REF. ONLY
UNLESS OTHERWISE SPECIFIED ALL DIMENSIONS ARE IN INCHES

NOTICE:
Use of this document is subject to a confidentiality and nondisclosure agreement with Great Lakes Case & Cabinet Co., Inc. (GLCC) and may not be reproduced, disclosed or utilized in whole or in part without prior written authorization from GLCC.

PART NUMBER: SEE CHART	
QTY PER UNIT: 1	
MATERIAL TYPE:	
MATERIAL GAUGE:	
FINISH:	
DRAWN CD	DATE 2/9/2011
CHECKED & APP. WSS	DATE 2/8/11

TITLE EN FRAME 84"H x 40"W x 48"D WITH SPLIT MESH FRONT AND REAR DOORS, SIDE AIRFLOW BAFFLE KIT AND 45 RMU RAILS	
GREAT LAKES CASE & CABINET CO., INC. P.O. BOX 551 EDINBORO, PA 16412 PHONE (814) 734-7303 FAX (814) 734-3907 E-MAIL glcc@greatcabinets.com	
DWG NO: SEE CHART	REV
SHEET: 1 OF 1	