

Bill of Material					
ITEM	PART NUMBER	QTY	DESCRIPTION	FILE NAME	REVISION
1	7206PKBX109	1	MOUSE TRAY BRACKET	I000419.iam	8
2	383418DOC	2	ACCURIDE SLIDE 19" TRAVEL DISCONNECT	383418DOC-assembly.iam	-
3	7206PKBMTX102	1	PIVOTING KEYBOARD TRAY	I000416.iam	8
4	7206PKBX104	2	PKB MOUNTING CHANNEL	I000417.ipt	6
5	-	2	PKB SHORT MOUNTING TAB	I000420.ipt	0
6	-	2	PKB LONG MOUNTING TAB	I000421.ipt	1
7	7206PKBX108	1	PIVOTING KEYBOARD BASE TRAY	I000418.ipt	6
11	10/32X1/25C23	5	#10-32 x 1/2" L PAN HEAD PHIL ZN PL TYPE 23 SC	10-32X5005C23.ipt	-
8	245W0010B	9	BLACK NYLON SHOULDER WA SHER - MICROPLASTICS	245W0010B.ipt	-
9	0501032LCNBLK	11	ACORN NUT, #10-32, BLACK NYLON, LOCKING	0501032LCNBLK.ipt	-
10	3710BKIMPRINT	1	SUNWAY WRIST REST W/ IMPRINT	3710BKIMPRINT.ipt	-
11	7206PKBMTX101	5	SLIDING MOUSE TRAY (PLASTIC)	I000415.ipt	3
13	POP RIVET - #SD-53-BS	12	POP RIVET 5/32" - K & L SALES (klsales.com)	POP RIVET - SD-53-BS.ipt	-

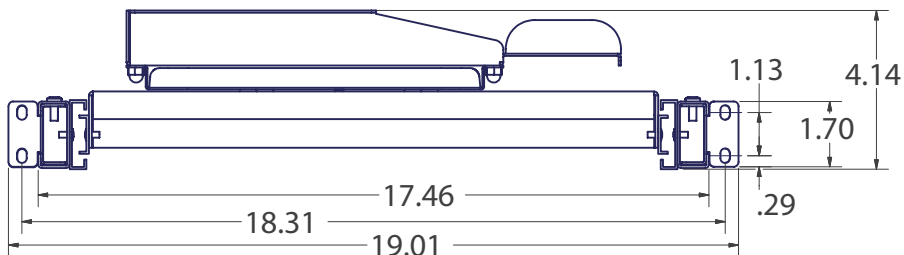
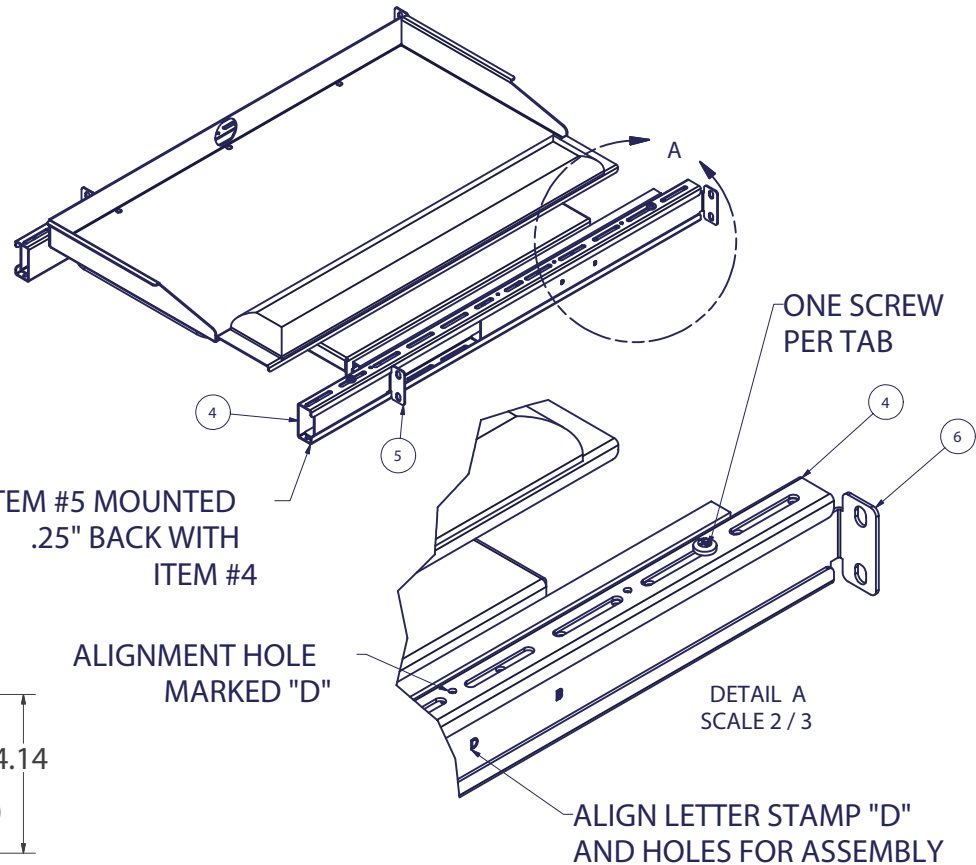

INTERPRET DRAWING PER ASME Y14.5M-1994
 DIMENSIONAL LIMITS APPLY
 AFTER APPLICATION OF FINISH
 DRAWING NOT TO SCALE
 TOLERANCE UNLESS OTHERWISE NOTED:
 ANGULAR $\pm 1^\circ$
 .XXXX $\pm .010$
 .XXX $\pm .015$
 .XX $\pm .030$
 X FOR REF. ONLY
 UNLESS OTHERWISE SPECIFIED
 ALL DIMENSIONS ARE IN INCHES

NOTICE:
 Use of this document is subject to a confidentiality and nondisclosure agreement with Great Lakes Case & Cabinet Co., Inc. (GLCC) and may not be reproduced, disclosed or utilized in whole or in part without prior written authorization from GLCC.

PART NUMBER:
7206PKBMT
 QTY PER UNIT: 1
 MATERIAL TYPE:
 MATERIAL GAUGE: #16 GA
 FINISH:
 DRAWN: WSS 6/27/02
 CHECKED:

TITLE
PIVOTING KEYBOARD SHELF ASSEMBLY
GREAT LAKES CASE & CABINET CO., INC.
 P.O. BOX 551 EDINBORO, PA 16412
 PHONE (814) 734-7303 FAX (814) 734-3907
 E-MAIL glcc@greatcabinets.com
 DWG NO: I000414
 REV: 9
 SHEET 1 OF 2

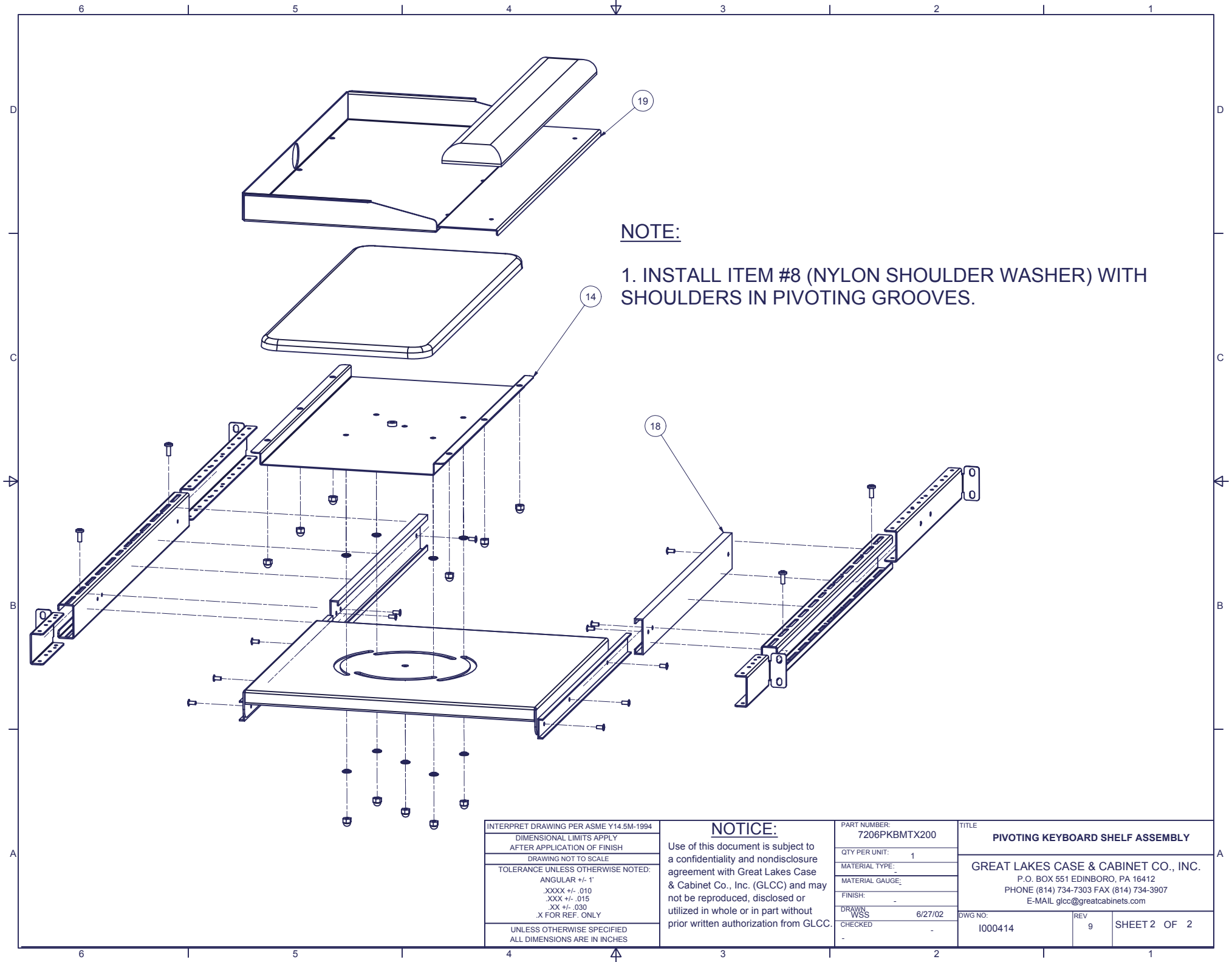

NOTE:

1. INSTALL ITEM #8 (NYLON SHOULDER WASHER) WITH SHOULDERS IN PIVOTING GROOVES.

INTERPRET DRAWING PER ASME Y14.5M-1994
 DIMENSIONAL LIMITS APPLY
 AFTER APPLICATION OF FINISH
 DRAWING NOT TO SCALE
 TOLERANCE UNLESS OTHERWISE NOTED:
 ANGULAR +/- 1'
 .XXXX +/- .010
 .XXX +/- .015
 .XX +/- .030
 .X FOR REF. ONLY
 UNLESS OTHERWISE SPECIFIED
 ALL DIMENSIONS ARE IN INCHES

NOTICE:
 Use of this document is subject to a confidentiality and nondisclosure agreement with Great Lakes Case & Cabinet Co., Inc. (GLCC) and may not be reproduced, disclosed or utilized in whole or in part without prior written authorization from GLCC.

PART NUMBER:
 7206PKBMTX200
 QTY PER UNIT: 1
 MATERIAL TYPE:
 MATERIAL GAUGE:
 FINISH:
 DRAWN: WSS 6/27/02
 CHECKED: -

TITLE PIVOTING KEYBOARD SHELF ASSEMBLY		
GREAT LAKES CASE & CABINET CO., INC. P.O. BOX 551 EDINBORO, PA 16412 PHONE (814) 734-7303 FAX (814) 734-3907 E-MAIL glcc@greatcabinets.com		
DWG NO: I000414	REV 9	SHEET 2 OF 2