

NO ASSEMBLY CHANGES:  
MODIFIED WIDTH OF DRAWER, MOUNTING TABS, & SLIDE CHANNEL

REVISION HISTORY			
REV	DESCRIPTION	DATE	APPROVED
13	ECO-03108	1/20/2011	FED

Bill of Material						
ITEM	PART NUMBER	STOCK NU	QTY	DESCRIPTION	FILE NAME	REVISION
1	7206DRX101		1	19" EIA SLIDING DRAWER SUB ASSEMBLY	I001170.iam	9
2	XL01	H17-012	1	STANDARD LOCK KEYED C415A	XL01.iam	-
3	31241650		2	SLIDE, 16", 17 1/2" TRAVEL, BAYONET ATTACHMENT, DISCONNECT	3124 1650 - 7206DR.iam	-
4	7206DRX106		2	SHORT EIA MOUNTING BRACKET FOR DRAWER	I001179.iam	5
5	7206DRX107		2	LONG EIA MOUNTING BRACKET FOR DRAWER	I001180.iam	5
6	P2-42		2	SNAP-IN PULL HANDLE, SOUTHCO - BLACK	P2-42.ipt	-
7	SCR832X375BLK	H01-047	4	#8-32 x 3/8"L PAN HEAD PHIL ZN PL TYPE 23 SCREW	SCR832X375BLK.ipt	-
8	7206DRX109		2	SLIDING DRAWER CHANNEL, 22.268" LENGTH	I001181.ipt	7
9	-		16	#8-32 x 1/4"L PAN HEAD PHIL TYPE 23 SCREW, ZINC PLATED	SCR832X250BLK.ipt	-

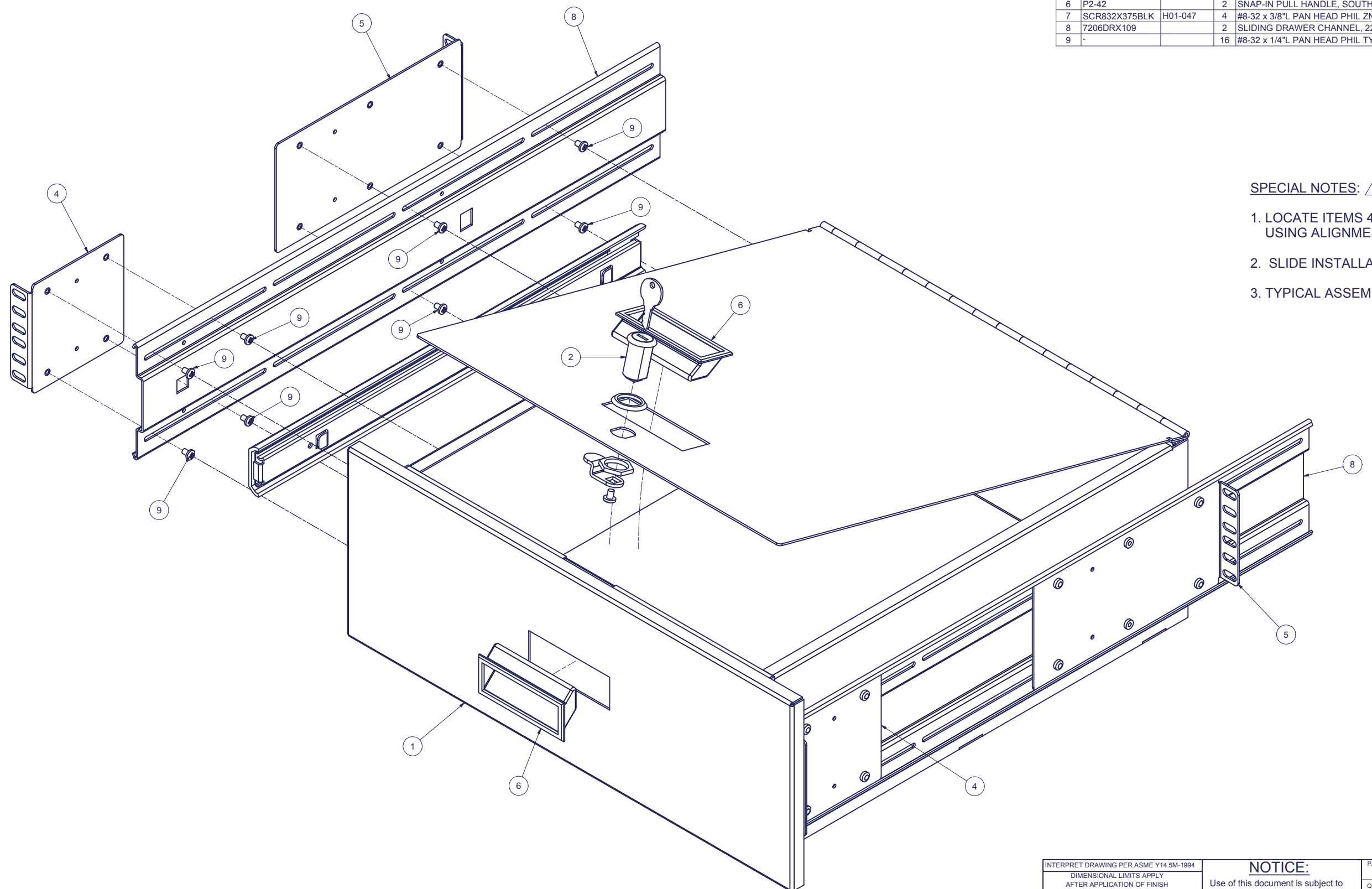

- SPECIAL NOTES:** 13
- LOCATE ITEMS 4 & 5 (MOUNTING TABS) ON ITEM 8 (CHANNEL) USING ALIGNMENT HOLES FOR PROPER SPACING.
  - SLIDE INSTALLATION ON SHEET 2.
  - TYPICAL ASSEMBLY FOR BOTH SIDES.

7206-DR SPECIFICATIONS	
DIMENSIONS: 16.000W x 18.875D x 7.000H	
WEIGHT CAPACITY: 100 LBS.	
MAX. TAB PLACEMENT: 25.500"	
RMU 4	
MATERIAL : 16 GA. CRS	
ACTUAL SLIDE TRAVEL: 17.50 MAX.	

INTERPRET DRAWING PER ASME Y14.5M-1994 DIMENSIONAL LIMITS APPLY AFTER APPLICATION OF FINISH DRAWING NOT TO SCALE TOLERANCE UNLESS OTHERWISE NOTED: ANGULAR +/- .1 .XXXX +/- .010 .XXX +/- .015 .XX +/- .030 .X FOR REF. ONLY	<b>NOTICE:</b> Use of this document is subject to a confidentiality and nondisclosure agreement with Great Lakes Case & Cabinet Co., Inc. (GLCC) and may not be reproduced, disclosed or utilized in whole or in part without prior written authorization from GLCC.	PART NUMBER: <b>7206DR</b>	TITLE <b>19"EIA SLIDING DRAWER - TOP LEVEL ASSEMBLY</b>		
		QTY PER UNIT: 1	GREAT LAKES CASE & CABINET CO., INC. P.O. BOX 551 EDINBORO, PA 16412 PHONE (814) 734-7303 FAX (814) 734-3907 E-MAIL glcc@greatcabinets.com		
		MATERIAL TYPE: CRS	DRAWN DATE CA 2/14/2003		
		MATERIAL GAUGE: #16 GA	CHECKED & APP. DATE AL 2-14-03		
UNLESS OTHERWISE SPECIFIED ALL DIMENSIONS ARE IN INCHES		FINISH: SEE NOTES	DWG NO: <b>I001169</b>	REV <b>13</b>	SHEET: 1 OF 3



8 7 6 5 4 3 2 1

INNER SLIDE DETAIL

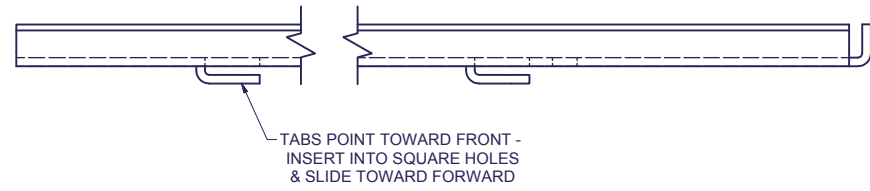

OUTER SLIDE DETAIL

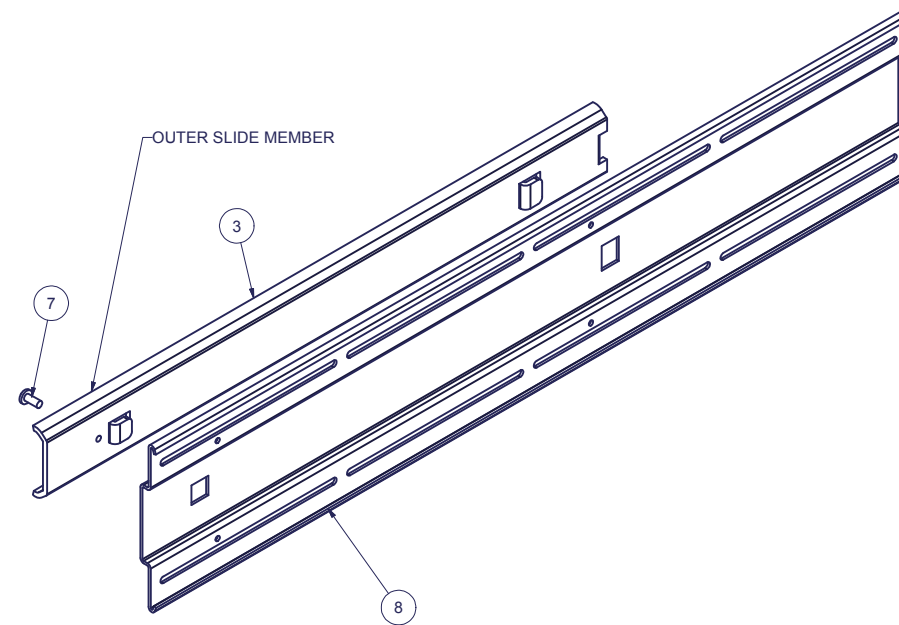
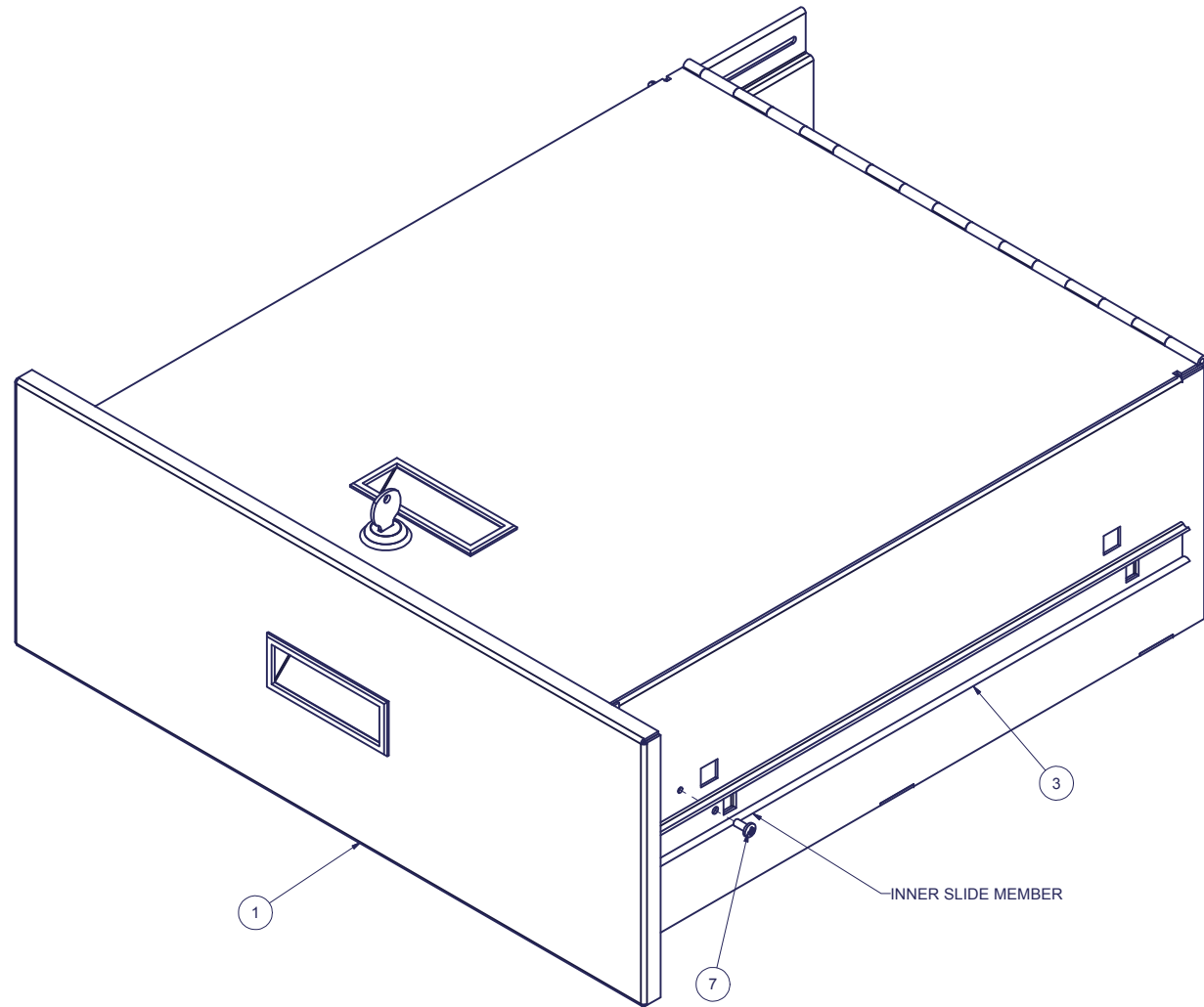
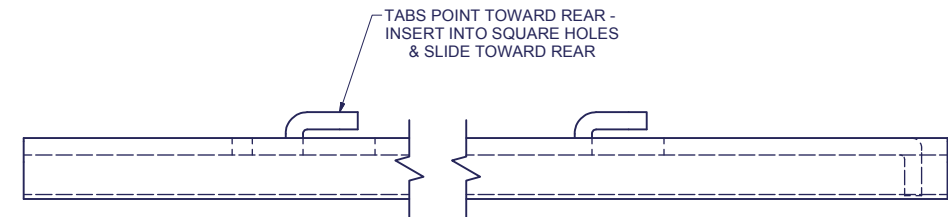

SPECIAL NOTES:

1. BEARING RACE MEMBER OF SLIDE NOT SHOWN FOR CLARITY.\
2. SECURE BOTH INNER & OUTER SLIDE MEMBERS WITH ITEM 7 (SCREW)

INTERPRET DRAWING PER ASME Y14.5M-1994  
 DIMENSIONAL LIMITS APPLY  
 AFTER APPLICATION OF FINISH  
 DRAWING NOT TO SCALE  
 TOLERANCE UNLESS OTHERWISE NOTED:  
 ANGULAR +/- 1°  
 .XXXX +/- .010  
 .XXX +/- .015  
 .XX +/- .030  
 .X FOR REF. ONLY

**NOTICE:**

Use of this document is subject to a confidentiality and nondisclosure agreement with Great Lakes Case & Cabinet Co., Inc. (GLCC) and may not be reproduced, disclosed or utilized in whole or in part without prior written authorization from GLCC.

PART NUMBER:  
**7206DRX200**  
 QTY PER UNIT: 1  
 MATERIAL TYPE:  
 MATERIAL GAUGE:  
 FINISH:  
 DRAWN DATE: 2/14/2003  
 CA  
 CHECKED & APP. DATE: 2-14-03  
 AL

TITLE  
**19"EIA SLIDING DRAWER - TOP LEVEL ASSEMBLY**  
 GREAT LAKES CASE & CABINET CO., INC.  
 P.O. BOX 551 EDINBORO, PA 16412  
 PHONE (814) 734-7303 FAX (814) 734-3907  
 E-MAIL glcc@greatcabinets.com  
 DWG NO: **1001169**  
 REV: **13**  
 SHEET: 2 OF 3



8 7 6 5 4 3 2 1

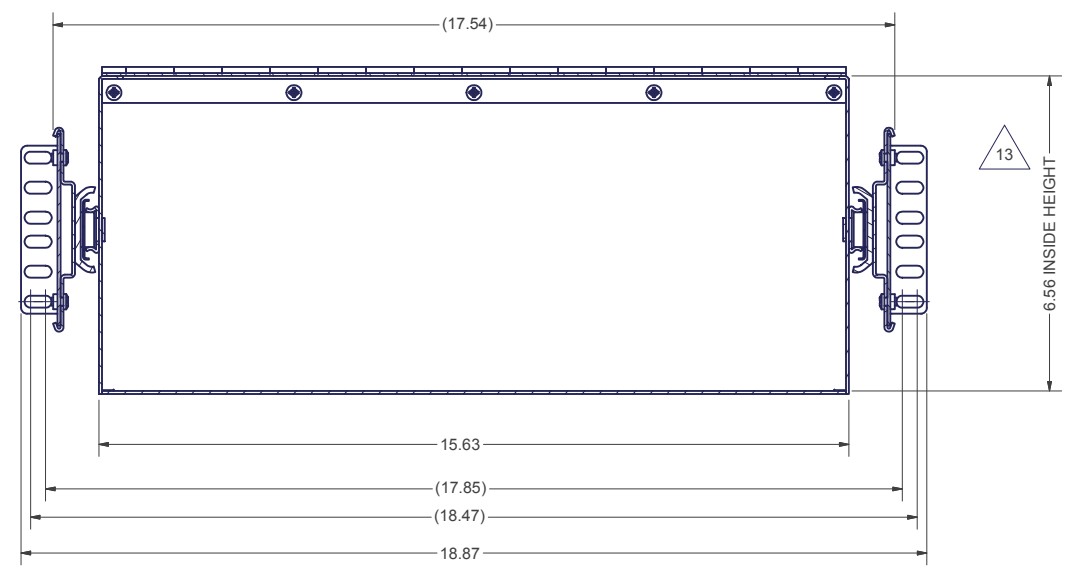
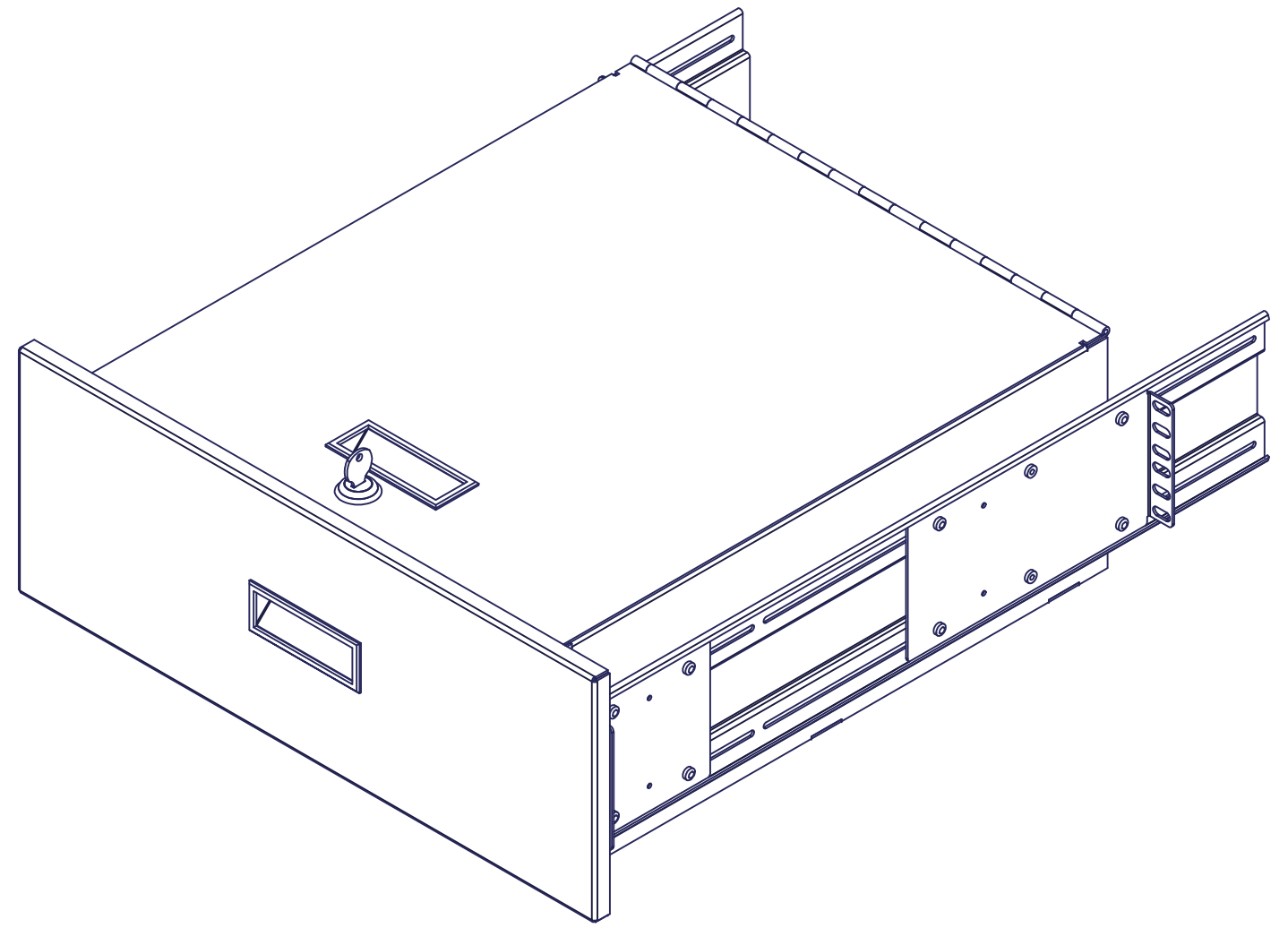
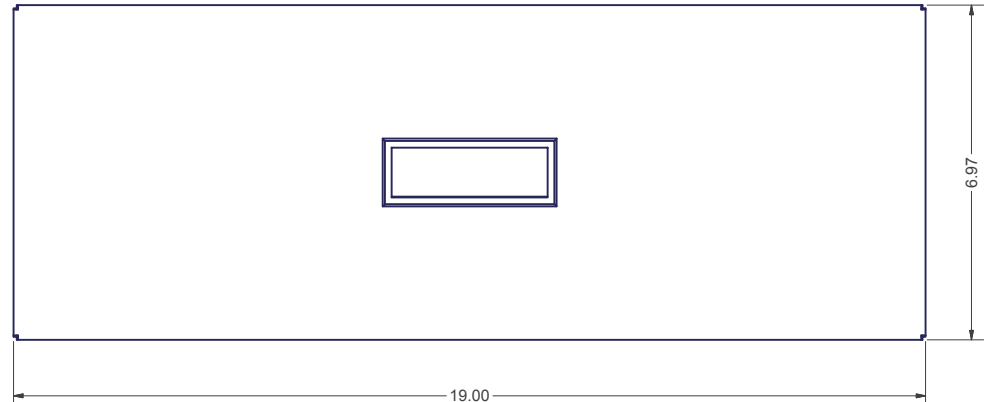
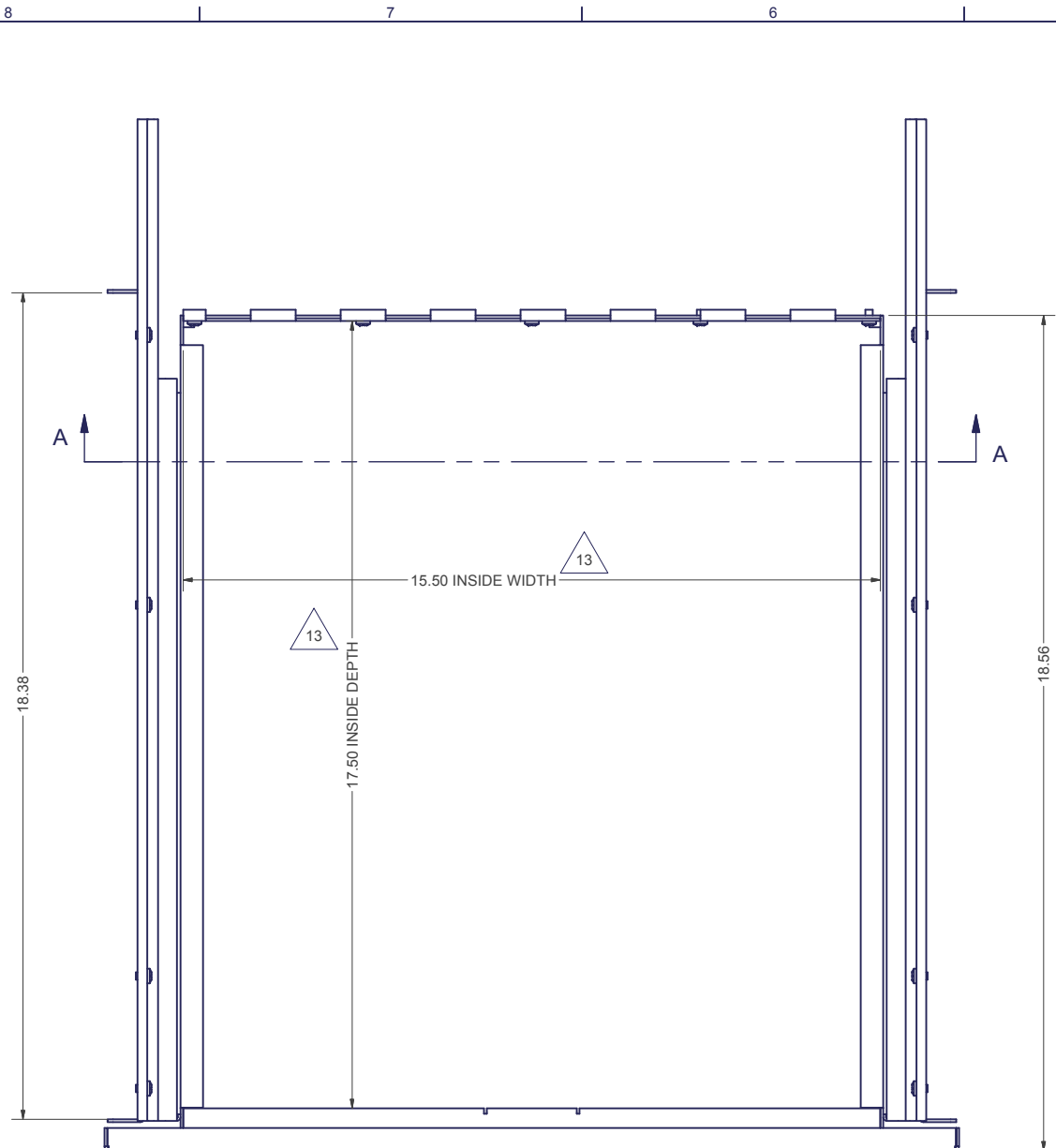

SECTION A-A

INTERPRET DRAWING PER ASME Y14.5M-1994  
 DIMENSIONAL LIMITS APPLY  
 AFTER APPLICATION OF FINISH  
 DRAWING NOT TO SCALE  
 TOLERANCE UNLESS OTHERWISE NOTED:  
 ANGULAR +/- .1°  
 .XXXX +/- .010  
 .XXX +/- .015  
 .XX +/- .030  
 .X FOR REF. ONLY

**NOTICE:**  
 Use of this document is subject to a confidentiality and nondisclosure agreement with Great Lakes Case & Cabinet Co., Inc. (GLCC) and may not be reproduced, disclosed or utilized in whole or in part without prior written authorization from GLCC.

PART NUMBER: <b>7206DRX200</b>	
QTY PER UNIT:	1
MATERIAL TYPE:	-
MATERIAL GAUGE:	-
FINISH:	-
DRAWN	DATE
CA	2/14/2003
CHECKED & APP.	DATE
AL	2-14-03

TITLE <b>19"EIA SLIDING DRAWER - TOP LEVEL ASSEMBLY</b>	
GREAT LAKES CASE & CABINET CO., INC. P.O. BOX 551 EDINBORO, PA 16412 PHONE (814) 734-7303 FAX (814) 734-3907 E-MAIL glcc@greatcabinets.com	
DWG NO: <b>1001169</b>	REV <b>13</b>
SHEET: 3 OF 3	



THIRD ANGLE PROJECTION  
 UNLESS OTHERWISE SPECIFIED  
 ALL DIMENSIONS ARE IN INCHES